

Series M15 Modular

- *Modular, Incremental Encoder for Stepper and Small Servo Motor Feedback*
- *Phased Array Sensor Technology Provides High Temperature and Operating Frequency and Allows 0.03" (0.76 mm) of Axial Play*
- *Resolutions to 1024 PPR with Index Standard; Optional 4, 6, or 8 Pole Commutation Tracks for Brushless Servo Motors*
- *Easy Installation and Removal without Special Tools or Parts*

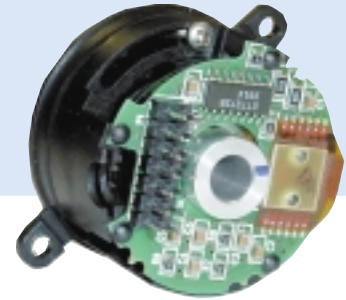

MOTOR MOUNT

APPLICATION/INDUSTRY

The Dynapar brand M15 modular encoder provides high-performance, cost effective feedback for stepper and servo motor controls.

DESCRIPTION

Using industry standard package dimensions, the M15 is easily installed onto the motor without time-consuming adjustments or special tools. Its unique mechanical design automatically centers and gaps the disc during installation.

For Brushless DC (BLDC) servo control, optional 3 phase commutation tracks replace the traditional Hall Effect sensors. These optically-generated signals provide higher accuracy and reliability, improving the performance and reliability of the servo system.

FEATURES AND BENEFITS

- Operates up to 120°C. The high temperature plastics, phased array sensor, and low current requirements stabilize the output signals over a wide range of input voltage, ambient temperature, or output frequencies.
- Provides 30 degrees of adjustment to align the signal outputs to the shaft position. Using an industry standard Size 15 modular mounting pattern, the index mark on the disc hub can be coarse aligned to the index sensor position on the housing. The housing rotates to allow further adjustment of the index or fine alignment of the commutation channels to the BLDC motor windings.
- Enclosure is dirt-tight, rated NEMA 1 / IP40. The cover is gasketed to seal the disc and optics from contamination. Additionally, the base can be sealed to the motor for further environmental protection.
- Outputs are protected from short circuits, and operate on 5 or 12 VDC power.

SPECIFICATIONS

STANDARD OPERATING CHARACTERISTICS

Code: Incremental
Resolution: (pulses/revolution)
 Incremental: 200 to 1024 PPR;
 Commutation: 4, 6, or 8 pole
Accuracy:
 Incremental: ± 5 arc-mins. max. edge to edge;
 Commutation: ± 6 arc-mins. max.
Sense: (viewing encoder mounting surface)
 Incremental: A leads B by 90° for CCW rotation of motor shaft;
 Commutation: U leads V, V leads W by 120° for CW rotation of motor shaft
Phasing:
 Incremental: 90° $\pm 18^\circ$ electrical
 Commutation: 8 Pole: 30°; 6 Pole: 40°; 4 Pole: 60° mechanical
 Index to U Channel: $\pm 1^\circ$ mechanical - Index center to U channel edge
Symmetry:
 Incremental: 180° $\pm 18^\circ$ electrical
 Commutation: 8 Pole: 45°; 6 Pole: 60°; 4 Pole: 90° mechanical
Index Pulse Width: 180° $\pm 36^\circ$ electrical (Gated with B low) standard

ELECTRICAL

Input Power Requirements:
 Incremental: 5 or 12 VDC $\pm 10\%$ at 100 mA max. (excluding output load);
 Incremental w/Commutation: 5 or 12 VDC $\pm 10\%$ at 120 mA max. (excluding output load)
Output Signals:
 7272 Line Driver: 40 mA sink/source max.;
 Open Collector w/2.0 k Ω pull-ups: 16 mA sink max.
Frequency Response: 200 kHz min.
Termination:
 Connector: PCB mounted dual row head with 0.1" x 0.1" pin spacing, 10 pins (incremental only), 14 pins (w/commutation);
 Cable: conductors - 28 AWG, stranded (7/36), insulation - black, PVC; Shield: aluminum/polyester foil plus tinned, copper drain wire (28 AWG, 7/36)
Noise Immunity: Conforms to EN50082-1 Light Industrial for Electro-Static Discharge, Radio Frequency Interference, Electrical Fast Transients, and Magnetic Fields (for models or applications with shielded cable)

MECHANICAL

Weight:
 Connector: 0.8 oz. (23 gm) typ.
 Connector w/cover: 1.0 oz. (28 gm) typ.
 Cable: 1.3 oz (37 gm) typ.
 Cable w/cover: 1.5 oz. (43 gm) typ.
Dimensions:
 Outside Diameter: 1.60" (40.7 mm) max. w/ cover, 1.50" (38.2 mm) max. without cover;
 Height: 1.27" (32.3 mm) max. (w/cover, excluding connector);
 Emitter to Detector Gap: 0.070" (1.8 mm) min.
Material:
 Base, Housing, & Cover: high temperature, glass filled polymer;
 Hub: Aluminum; Disk: 0.030" thick glass
Finish:
 Base & Housing: black;
 Cover: RAL 7010 (dark grey)
Moment of Inertia: 3.40 x 10⁻⁵ in-oz sec.² (2.4 gm-cm²)
Hub Diameters: 1/8", 1/4", 3/8", 3/16", 6 mm, 8 mm, 10 mm nominal
Hub Dia. Tolerance: +0.001"/-0.000" (+0.026 mm/-0.000 mm)
Mating Shaft Length: 0.45" (12 mm) min.; 0.85" (22 mm) max. inside cover
Mating Shaft Runout: 0.002" (0.05 mm) max. (Includes shaft perpendicularity to mounting surface)
Mating Shaft Endplay: +0.015"/-0.015" (+0.38 mm/-0.38 mm) nominal ("+" indicates away from mounting face)
Mounting:
 Base: (2) #4-40 (M2.5) #1 Phillips fillister head cap screw on 1.812" (46 mm) B.C., or (2) #2-56 (M2.0) hex socket cap screw on 1.28" (32.5 mm) B.C.; 0.01" (0.254 mm) true position to shaft.
 Shaft: split hub w/collar clamp, #2-56 hex socket cap screw (5/64" hex wrench included)
Electrical/Mechanical Alignment Range: $\pm 15^\circ$ mechanical
Acceleration: 100,000 rad/sec.² max.
Velocity: 12,000 RPM max.

ENVIRONMENTAL

Operating Temperature: -40° to 120°C
Storage Temperature: -40° to 85°C
Shock: 50 G's for 11 msec duration
Vibration: 2.5 G's at 5 to 2000 Hz
Relative Humidity: 90% non-condensing
Enclosure Rating: NEMA 1 / IP40 dirt-tight (for models with cover)

Series M15 Modular

Dimensions/Installation

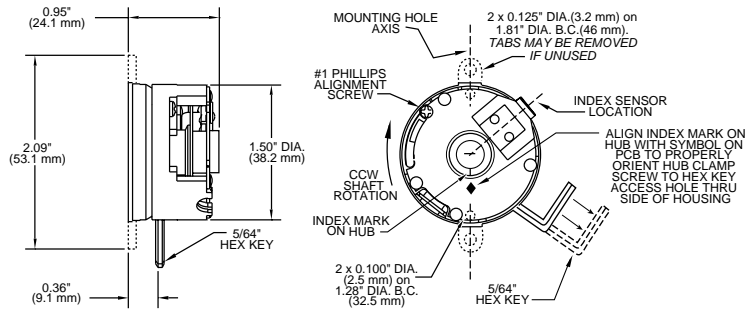

Installation Instructions:
 Incremental only models: Drawing #200638-0001
 Commutation models: Drawing #200638-0002

Output Waveforms (For clarity, compliments are not shown.)

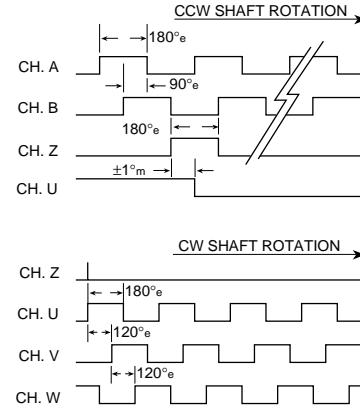

Code 6: Terminations (Not all signals present on all models)

0: Pin Header

1-8: Ribbon Cable

A-H: Shielded Cable

Pin	10 Pin		14 Pin
	O.C.	L.D.	
1	A	—	Vcc
2	Vcc	Vcc	U
3	GND	GND	U'
4	—	—	V
5	—	A'	V'
6	—	A	W
7	—	B'	W'
8	B	B	A'
9	—	Z'	A
10	Z	Z	B
11	—	—	B'
12	—	—	Z
13	—	—	GND
14	—	—	Z'

Mating Cable Assembly:
 10 pin, 109524-000x
 14 pin, 110527-000x
 x = length in feet

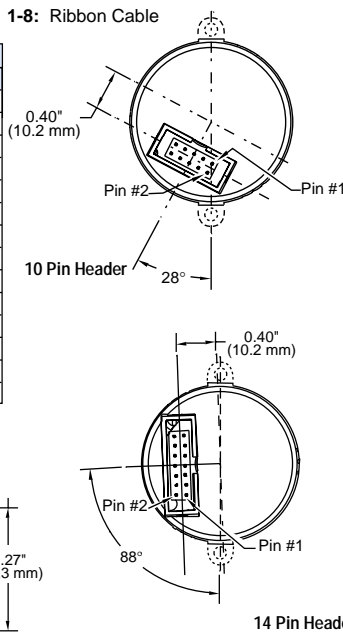
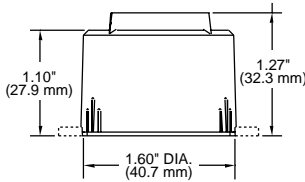

Function	Wire Color	
	Incr. Only	Incr. & Comm.
Vcc com	—	RED/WHT
Vcc Inc	RED	RED
GND Inc	BLK	BLK
GND com	—	BLK/WHT
A'	RED/BLK	BLU/BLK
A	GRN	BLU
B'	WHT/BLK	GRN/BLK
B	ORN	GRN
Z'	BLU	VIO/BLK
Z	WHT	VIO
U'	—	BRN/BLK
U	—	BRN
V'	—	GRY/BLK
V	—	GRY
W'	—	WHT/BLK
W	—	WHT

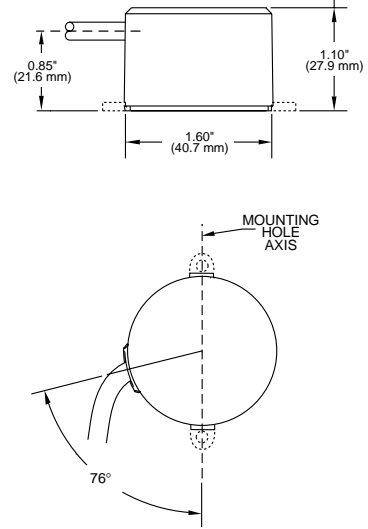

Ordering Information

To order, complete the model number with code numbers from the table below:

Code 1: Model	Code 2: PPR, Poles	Code 3: Cover	Code 4: Electrical	Code 5: Hub	Code 6: Termination
M15	<input type="checkbox"/> <input type="checkbox"/> <input type="checkbox"/> <input type="checkbox"/> <input type="checkbox"/>	<input type="checkbox"/>	<input type="checkbox"/>	<input type="checkbox"/>	<input type="checkbox"/>

Ordering Information						
M15	Size 15 Commutating Modular	Incremental channels only		0 No cover 1 Enclosed, end-of-shaft mount 2 Through shaft	0 5V in, open collector out incremental only 1 12V in, open collector out incremental only 3 5V in, line driver out incremental only Available when Code 2 is XXXX/4, XXXX/6, or XXXX/8 6 5V in, line driver out incr.; 5V in, open collector out comm. 7 5V in, line driver out incr.; 12V in, open collector out comm. 9 5V in, line driver out incr.; 5V in, line driver out comm.	0 1/4 in. 1 3/8 in. 4 6 mm 5 8 mm 6 10 mm 8 3/16 in. 9 1/8 in.
		Incremental plus Commutation channels				
		0200/0	1000/0			
		0400/0	1024/0			
		0500/0				
		0500/6	1024/4			
		1000/4	1024/6			
		1000/6	1024/8			
		1000/8				