

Series F10 Commutating

- Replaces Size 10 Pancake Resolver
- Compact (1.25" Diameter)
- Resolution to 2048 PPR
- Accuracy to ± 2.5 arc-min
- Operating temperature to 120° C does not limit motor performance
- Operating frequency to 300 kHz for fast servo loops



M
O
T
O
R

M
O
U
N
T

APPLICATION/INDUSTRY

The Dynapar brand Series F10 encoder provides high performance, cost effective feedback for stepper and servo motor applications.

DESCRIPTION

The F10 offers compact package dimensions and flying leads for a low-profile installation. A size 10 servo ring allows easy mounting and replacement of pancake resolvers with high tolerance to motor shaft movement and 360 degrees of adjustment to align the signal outputs to the shaft position.

A superior optical configuration allows for generous internal component clearance eliminating potential damage at high ambient operating temperatures. High temperature rated grease is standard for extended bearing life.

The use of optically-generated signals for Brushless DC (BLDC) servo control provides higher accuracy and reliability by eliminating the hysteresis found in competitive units with hall-effect sensors, ensuring maximum performance and reliability of the servo system. Compared to most resolvers with accuracy of ± 10 arc-min, the F10 enables superior shaft positioning with accuracy to ± 2.5 arc-min.

FEATURES AND BENEFITS

- The F10 design operates up to 120°C. High temperature materials, innovative phased array sensor technology, and low current requirements stabilize the output signals over a wide range of ambient temperature and output frequencies.
- The F10 mounting configuration allows for direct pancake resolver replacement featuring a jamb nut and tethered servo ring.

SPECIFICATIONS

STANDARD OPERATING CHARACTERISTICS

Code: Incremental with commutation option, Optical
Resolution: 1024 or 2048 PPR incremental with 6 pole commutation channels
Accuracy: Incremental: ± 2.5 arc-mins. max. edge to any edge; Commutation: ± 6 arc-mins. max.
Phasing for CCW rotation of motor shaft : B leads A by 90° and U leads V leads W by 120°.
Minimum edge separation A to B is 45°.
Index to U channel: +/- 1° mech. index pulse center to U channel edge.
Index Pulse Width: 90° gated A and B low

ELECTRICAL

Input Power Requirements: 5 \pm 10% VDC at 100 mA max (incremental and commutation), excluding output load
Output Signals:
Incremental: 26LS31 Differential Line Driver, sink / source 40 mA max.
Commutation: Open Collector w/2.0 k Ω pull-ups, 8 mA sink max.; or 26LS31 Differential Line Driver, sink / source 40 mA max.
Frequency Response: 300 kHz, max.
Termination: Flying leads, stranded 26 AWG, twisted pair, PVC insulation, 6.5" length ± 0.5 "

MECHANICAL

Weight: 1.6 oz. (45 gm) typ.
Dimensions: Outside Diameter : 1.25" (31.7mm), max.; Height: 0.89" (24.1mm), max.
Material: Housing: cast-aluminum;
 Servo Ring: glass reinforced engineering resin;
 Hub: Brass; Disk: 0.030" (0.76mm) thick glass
Moment of Inertia: 2.22X10⁻⁵ in-oz-sec.² (1.6 gm-cm²)
Bore Diameter: 6mm
Bore Dia. Tolerance: +0.001"/-0.000" (+0.025 mm/-0.000 mm)
Mating Shaft Runout: 0.002" (0.05 mm) max. (Includes shaft perpendicularity to mounting surface)
Mating Shaft Axial movement: ± 0.010 " (± 0.25 mm)
Mounting: 1.045" (26.54mm) servo ring with integral flexure (size 10 pancake resolver equivalent)
Acceleration: 100,000 rad/sec.² max.
Velocity: 5,000 RPM continuous; 12,000 RPM peak
Bearing Life: [(3.6 X 10⁹) / RPM] Hours ; e.g. 605,000 hours @6,000 RPM

ENVIRONMENTAL

Operating Temperature: 0° to +120°C
Storage Temperature: 0° to +120°C
Shock: 50 Gs for 6 msec duration
Vibration: 2.5 Gs at 5 to 2000 Hz
Relative Humidity: 90% non-condensing

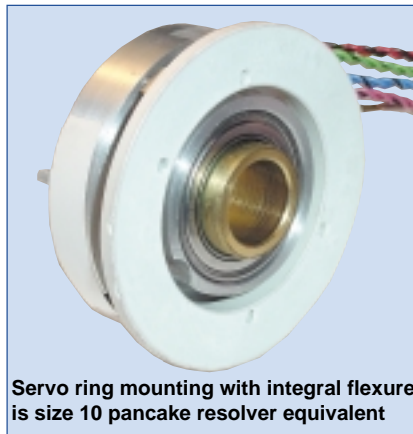

Servo ring mounting with integral flexure is size 10 pancake resolver equivalent

Series F10 Commutating

Dimensions

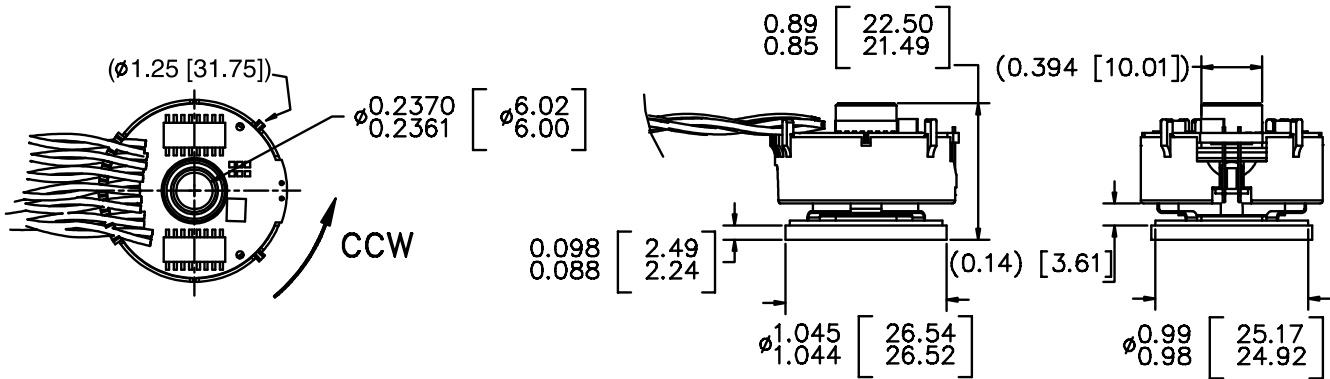

Connections

Function*	Cable Wire Color
VCC	RED
GND	BLACK
A	BLUE/BLACK
A	BLUE
B	GREEN/BLACK
B	GREEN
Z	VIOLET/BLACK
Z	VIOLET
U	BROWN/BLACK
U	BROWN
V	GRAY/BLACK
V	GRAY
W	WHITE/BLACK
W	WHITE

* Function availability dependant on Model

Waveforms

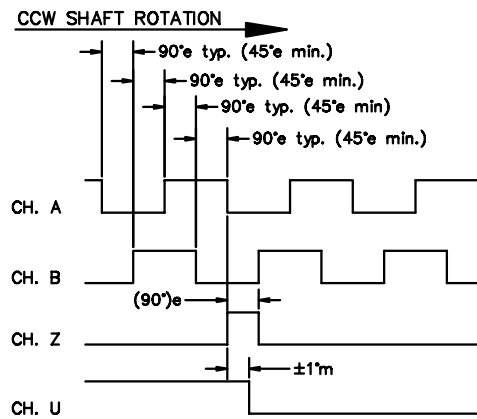

Waveforms below show relationship between CH. Z, U, V & W (scale differs from above)

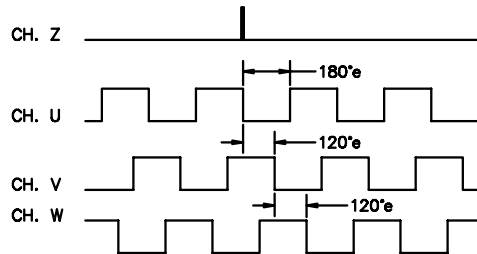

Ordering Information

To order, complete the model number with code numbers from the table below:

Code 1: Model	Code 2: PPR, Poles	Code 3: Mount	Code 4: Electrical	Code 5: Shaft/Bore	Code 6: Termination
F10	<input type="checkbox"/> <input type="checkbox"/> <input type="checkbox"/> <input type="checkbox"/> <input type="checkbox"/>	<input type="checkbox"/> <input type="checkbox"/> <input type="checkbox"/> <input type="checkbox"/>	<input type="checkbox"/> <input type="checkbox"/> <input type="checkbox"/> <input type="checkbox"/>	<input type="checkbox"/> <input type="checkbox"/> <input type="checkbox"/> <input type="checkbox"/>	<input type="checkbox"/> <input type="checkbox"/> <input type="checkbox"/> <input type="checkbox"/>
Ordering Information					
F10 Size 10 Commutating Encoder	Incremental channels only 1024/0 2048/0	0 Servo mount 1.045 Diameter x .095 thick	Available when Code 2 is XXXX/0 3 5V in, line driver out incremental only	4 6mm thru bore	0 6.5" ±0.5" Twisted Pair Flying Leads
	Incremental plus Commutation channels 1024/6 2048/6		Available when Code 2 is XXXX/6 6 5V in, line driver out for incremental; 5V in, open collector out for commutation 9 5V in, line driver out for incremental; 5V in, line driver out for commutation		

MOTOR MOUNT