

Series E14 Integral Coupling

- Standard Mounting on NEMA Size 23 and 34 Motors
- Direct Replacements for Compumotor –E Option for Stepper Motors/Drives

Compumotor Equivalent Models:

For Size 23 Stepper Motor: E14-1000-A863
For Size 34 Stepper Motor: E14-1000-C863

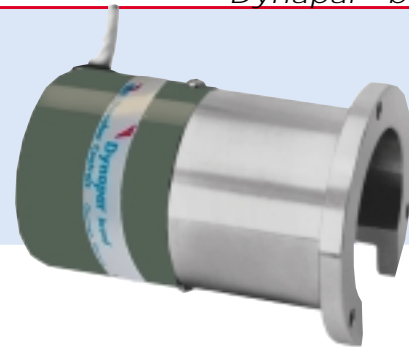

MOTOR MOUNT

APPLICATION/INDUSTRY

The E14 with Integral Shaft Coupling is designed for convenient motor installation. It mounts on industry standard bolt circle patterns and is available to accommodate a choice of shaft sizes.

Typical Applications

- Motor-mounted feedback
- Industrial equipment
- Assembly machinery
- Robotics

DESCRIPTION

The Series E14 includes precision bearings and an O-ring seal and accommodates a 1/4" or 3/8" diameter stainless steel shaft.

Series E14 incorporates the latest in microelectronic packaging, LED light sources, and matched sensors. Outputs are designed to be compatible with most 5V TTL circuits with options for higher voltage 12 and 15 VDC. Shielded cable is standard. Line drivers with complementary outputs are available for longer cable runs and/or higher ambient electrical noise immunity.

FEATURES AND BENEFITS

Mechanical and Environmental Features

- Durable metal housing
- O-ring housing seal
- Accommodates rugged 1/4" or 3/8" diameter stainless steel shafts
- Up to 5000 RPM

Electrical Features

- Up to 2540 pulses per revolution including an optional marker pulse
- Higher electronic operating speed up to 100 kHz
- LED light source and matched sensors
- Choice of 5, 12, or 15 VDC units
- Shielded cable and line driver available for higher electrical noise immunity

SPECIFICATIONS

STANDARD OPERATING CHARACTERISTICS

Code: Incremental
Resolution: 100 to 2540 PPR (pulses/revolution)
Format: Two channel quadrature (AB) with optional Index (Z) outputs
Phase Sense: A leads B for CW shaft rotation as viewed from the shaft end of the encoder; Reverse phasing available, see Ordering Information
Accuracy: $\pm 3 \times (360^\circ \div \text{PPR})$ or ± 2.5 arc-min worst case pulse to any other pulse, whichever is less
Quadrature Phasing: $90^\circ \pm 36^\circ$ electrical
Symmetry: $180^\circ \pm 18^\circ$ electrical
Index: $90^\circ \pm 25^\circ$ (gated with A and B high)
Waveforms: Squarewave with rise and fall times less than 1 microsecond into a load capacitance of 1000 pF

ELECTRICAL

Input Power:
 5 VDC $\pm 5\%$ at 80 mA max.;
 12 or 15 VDC $\pm 10\%$ at 80 mA max.; not including output loads
Outputs:
 7272 line driver (or equivalent), 40 mA sink and source
 Frequency Response: 100 kHz min.

MECHANICAL

Bearing Life: $(16 \times 10^6 \div \text{RPM})$ hours min.
Shaft Speed: 5,000 RPM max.
Starting Torque: 0.1 oz-in max. at 25 °C
Running Torque: 0.08 oz-in max. at 25 °C
Moment of Inertia: 3.8×10^{-5} oz-in-sec²
Weight: 7.0 oz. max.

ENVIRONMENTAL

Operating Temperature: 0 to +70 °C
Storage Temperature: -25 to +70 °C
Humidity: to 98% without condensation
Enclosure Rating: NEMA12/IP54 (dirt tight, splashproof) Optional: NEMA 3/IP64 rating available (consult factory)

Series E14 Integral Coupling

Approximate Dimensions (inches/mm)

E14 for NEMA Size 23 Motors

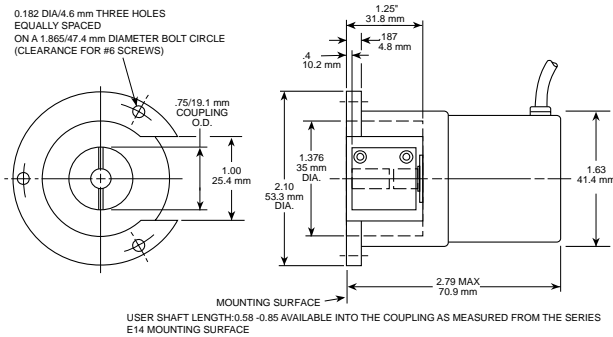

E14 for NEMA Size 34 Motors

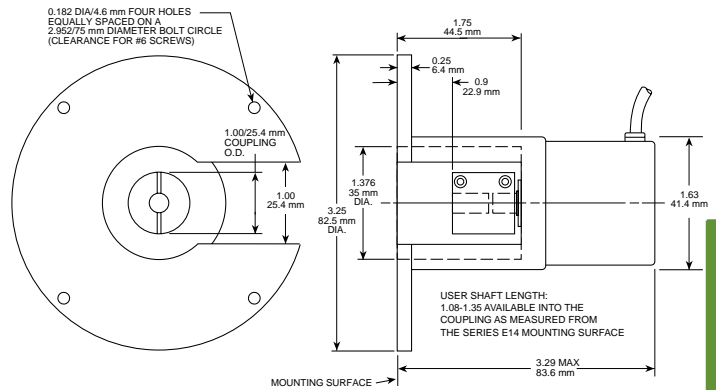

MOTOR MOUNT

Electrical Connections

Wire Color Code	Function			DB 25 Connector Pin Number
	Single Ended Outputs	Differential Outputs		
		Unidirectional	Bidirectional	
Red	Power Source	Power Source	Power Source	23
Black	Common	Common	Common	14
White	Signal A	Signal A	Signal A	1
Green	Signal B (if used)	Signal A	Signal B	3
Orange	Signal Z (if used)	No Connection	Signal B	4
Blue	No Connection	No Connection	Signal A	2
Shield	Floating	Floating	Floating	8
White/Black	—	—	Signal Z (if used)	5
Red/Black	—	—	Signal Z (if used)	6

Flange Adapter Ordering Codes

Factory Option Code	Motor Frame Size	Motor Shaft Diameter	Model No. of Coupling Only
A	23	1/4"	605106-1
B	23	3/8"	605106-3
C	34	3/8"	605106-3

Other couplings available; consult factory.

Field Installed Kit:

Field installed kits are available by ordering either Model No. E14-N1 (integral housing and mounting hardware for NEMA size 23 motors) or Model No. E14-N2 (integral housing & mounting hardware for NEMA size 34 motors), and the appropriate coupling listed in the table above.

Ordering Information

To order, complete the model number with code numbers from the table below:

Code 1: Model	Code 2: Pulses/Rev	Code 3: Mounting	Code 4: Mechanical	Code 5: Output	Code 6: Electrical	Code 7: Termination
E14	<input type="checkbox"/> <input type="checkbox"/> <input type="checkbox"/> <input type="checkbox"/>	<input checked="" type="checkbox"/>	<input type="checkbox"/>	<input type="checkbox"/>	<input type="checkbox"/>	<input type="checkbox"/>
E14 Size 14, with Integral Shaft Coupling	0100 1000 0200 1024 0240 1250 0250 1500 0256 2000 0300 2048 0360 2500 0400 2540 0500 0600 0720 0750 0900	0 Size E14	A NEMA Size 23 Flange Mount with 1/4" Motor Shaft Coupling B NEMA Size 23 Flange Mount with 3/8" Motor Shaft Coupling C NEMA Size 34 Flange Mount with 3/8" Motor Shaft Coupling	0 Single Ended, Unidirectional 2 Single Ended, Bidirectional, no Index 3 Single Ended, Bidirectional, with Index 4 Differential, Unidirectional 6 Differential, Bidirectional, no Index 7 Differential, Bidirectional, with Index 8 Differential, Bidirectional, with Index, Reversed Phasing	0 5 VDC 1 12 VDC 2 15 VDC	0 18" Cable 1 3' Cable 2 6' Cable 3 10' Cable 4 15' Cable available when Code 5 = 7 or 8: 5 10' Cable, DB25 Connector 7 25' Cable, DB25 Connector