

Series AI25 SSI Interface

- Up to 17 Bit single-turn resolution
- 4096 revolutions of multi-turn resolution
- Short installation depth
- Safety through self-diagnostics
- Solid shaft and hollow shaft versions
- -40°C to +100°C Operating temperature



ACURO



APPLICATION/INDUSTRY

The Dynapar brand ACURO Absolute Encoder offers a modern full-feature design equipped with SSI interface.

DESCRIPTION

The **Acuro AI25** optical absolute industrial encoder is available in a single-turn or multi-turn version. The multi-turn design is based on a reliable high-speed gear with optical scanning and the latest generation of OptoASIC technology.

The mechanical concept is based on a double ball bearing design, which is available as a solid-shaft or hollow-shaft version in common shaft diameters.

FEATURES AND BENEFITS

- Compact design to save valuable space
- Low power consumption
- Fast delivery of any model variant
- Additional field-bus and point-to-point interfaces available

SPECIFICATIONS

STANDARD OPERATING CHARACTERISTICS

Single-turn Resolution: 10, 12, 13, 14, 17 Bit
Multi-turn Resolution: 12 bit (only available with 12 or 13 bit ST resolution)
Linearity: +/- 1/2 LSB
Absolute Accuracy: ±0.01° mechanical (36 arc-sec.)
Repeatability: ±0.002° mechanical (7.2 arc-sec.)
Code format: Binary, Gray, Gray Excess, parameterization through *AcuroSoft*
Parameterization: Resolution code type, sense of rotation, warning, alarm

ELECTRICAL

Connection: Cable, M23 - 12 pole Conin connector, M12- 8-pole connector
Supply voltage: 5 VDC -5%/+10% or 10-30 VDC
Intrinsic current consumption: 50 mA (ST), 100 mA (MT) not including output current
Output current: 60 mA per bit, short circuit protected
Frequency response: 500 kHz
Maximum cable length: 400 m
Control Inputs: Direction
Alarm output: Alarm bit
Status LED: Green = OK, Red = Alarm (IP64 only)
Preset Switch: Sets encoder to zero output at present mechanical position (IP64 only)

MECHANICAL

Shaft diameter:
 Shaft: 6 mm (Servo Mount), 10 mm (Clamping Mount), 3/8" (Square Flange Mount)
 Hubshaft: 10mm, 12 mm, 3/8", 1/2"
Maximum shaft load:
 6 mm shaft: 13 lb axial, 24 lb radial
 10 mm shaft: 24 lb axial, 35 lb radial
Maximum shaft speed: 10,000 RPM (continuous), 12,000 RPM (peak)
Starting torque: < 1.4 in-oz
Weight (approx.): 350 g ST, 400 g MT
Shaft tolerance (hubshaft only): +/- 1.5 mm axial, +/- 0.2 mm radial
Flange configurations: Square, Clamp, Servo, Hubshaft with flexible tether
Bearing life:
 1 x 10¹⁰ revolutions at 35% full rated shaft load
 1 x 10⁹ revolutions at 75% full rated shaft load
 1 x 10⁸ revolutions at 100% full rated shaft load

ENVIRONMENTAL

Operating Temperature: -40 to 100° C
Storage Temperature: -40 to 100° C
Enclosure Rating: IP64 or IP67
Shock: 1,000 m/s² (6 ms)
Vibration: 100 m/s² (10 to 2,000 Hz)

ABSOLUTE

Code 1: Model	Code 2: Bits	Code 3 :Mounting	Code 4: Shaft Size	Code 5: Protocol	Code 6: Electrical	Code 7: Connector
AI25	<input type="checkbox"/> <input type="checkbox"/> <input type="checkbox"/> <input type="checkbox"/>	<input type="checkbox"/>	<input type="checkbox"/>	<input type="checkbox"/>	<input type="checkbox"/>	<input type="checkbox"/>
AI25 Size25 Acuro Absolute Encoder	Single-Turn	Available when Code 4 is 0 or A	w/o shaft seal (IP64) 0 6 mm 1 3/8" 2 10 mm 3 3/8" Hub Shaft 4 12 mm Hubshaft 5 1/2" Hubshaft 6 10 mm Hub Shaft	2 SSI Gray 3 SSI Binary	0 5 VDC 2 10-30 VDC	0 1.5m axial cable 1 1.5m radial cable 2 M23 Conin 12 pin axial CW 3 M23 Conin 12 pin radial CW C M12 , 8-pole connector axial D M12 , 8-pole connector radial
	0010 10 Bit	0 Servo*				
	0012 12 Bit	Available when Code 4 is 2 or C				
0013 13 Bit	1 Clamping*	Available when Code 4 is 1 or B	w/ shaft seal (IP67) A 6 mm B 3/8" C 10 mm			
0014 14 Bit	2 Square flange**					
0017 17 Bit	Available when Code 4 is 3, 4, 5 or 6					
Multi-Turn	1212 12 Bit Multi-Turn, 12 Bit Single-Turn	3 Hubshaft w/tether†				
	1213 12 Bit Multi-Turn, 13 Bit Single-Turn	* 58mm Dia. ** 2.5" Square † 63mm BC				

Series AI25 SSI Interface

Code 3: Mounting

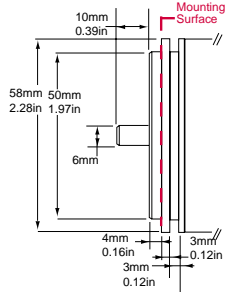
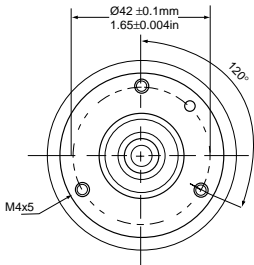

0
Servo

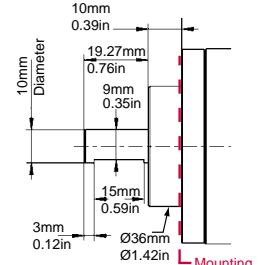
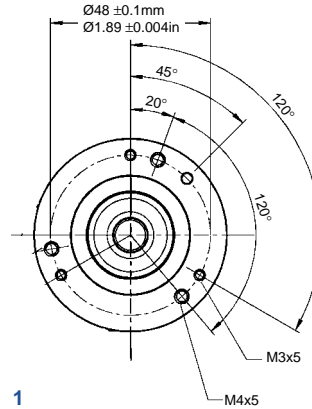

1
Clamping

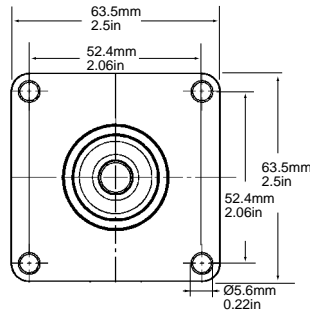
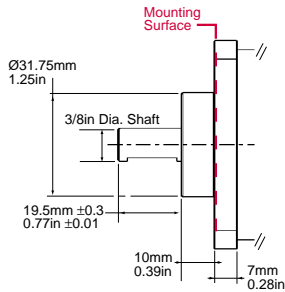

2
Square Flange

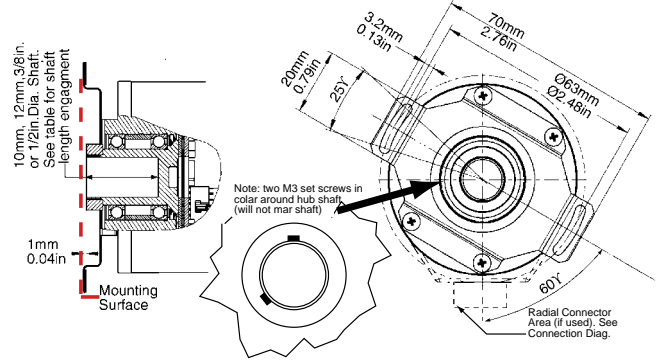

Hubshaft Shaft Engagement

HubShaft Diameter	Min. Shaft Length	Max. Shaft Length
10mm, 3/8"	15mm (0.59")	20mm (0.79")
12mm, 1/2"	18mm (0.71")	20mm (0.79")

3
Hubshaft w/Tether

Code 7: Connector

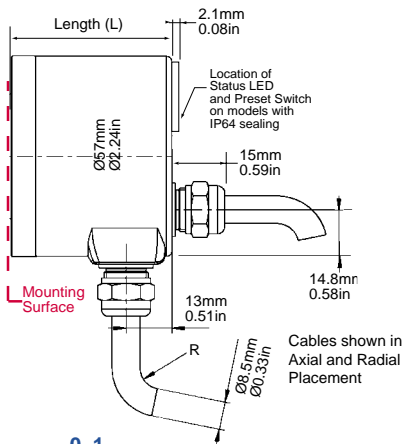

0, 1
2 1.5M Cable

Length (L) Mounting Surface to Rear

Mount (Code 3)	Single-Turn	Multi-Turn
(0) Servo	46.5/1.83	46.5/1.83
(1) Clamping	45.5/1.79	45.5/1.79
(2) Square Flng	45.5/1.79	45.5/1.79
(3) Hubshaft	53.4/2.1	53.4/2.1

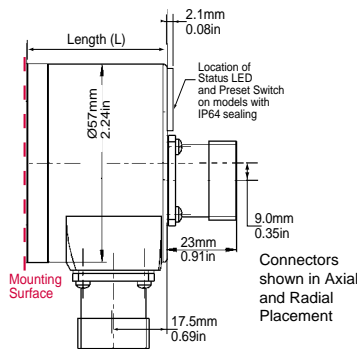

2, 3
Conin 12 Pin Connector

Length (L) Mounting Surface to Rear

Mount (Code 3)	Single-Turn	Multi-Turn
(0) Servo	46.5/1.83	46.5/1.83
(1) Clamping	45.5/1.79	45.5/1.79
(2) Square Flng	45.5/1.79	45.5/1.79
(3) Hubshaft	53.4/2.1	53.4/2.1

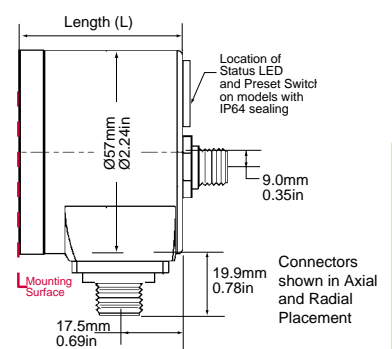

C, D
M12, 8-pole Connector

Length (L) Mounting Surface to Rear

Mount (Code 3)	Single-Turn	Multi-Turn
(0) Servo	46.5/1.83	46.5/1.83
(1) Clamping	45.5/1.79	45.5/1.79
(2) Square Flng	45.5/1.79	45.5/1.79
(3) Hubshaft	53.4/2.1	53.4/2.1

Series AI25 SSI Interface

SSI Data Format

Bits	T1 - T10	T11	T12	T13	T14	T15	T16	T17	T18	T19
10	S9 - S0	0	0	0	0	S9	S8	S7	S6	S5
12	S11 - S2	S1	S0	0	0	S11	S10	S9	S8	S7
13	S12 - S3	S2	S1	S0	0	S12	S11	S10	S9	S8
14	S13 - S4	S3	S2	S1	S0	0	S13	S12	S11	S10
17	S16 - S7	S6	S5	S4	S3	S2	S1	S0	0	S16

Bits	T1 - T12	T13 - T21	T22	T23	T24	T25	T26	T27	T28	T29
1212	M11 - M0	S11 - S3	S2	S1	S0	0	0	M11	M10	M9
1213	M11 - M0	S12 - S4	S3	S2	S1	S0	0	M11	M10	M9

S9, S8 Data Bits for resolution per turn.

S9 - S0 Data Bits S9, S8, S7, S6, S5, S4, S3 Etc.

M11, M10 Data Bits for number of turns.

M11- M0 Turn Data Bits M11, M10, M9, M8, Etc.

T1, T2 SSI Clock number

Electrical Connections 12 pin CONIN

Wire Color	Pin	Function
Brown	1	0V
Pink	2	Data
Yellow	3	Clock
—	4	N.C.
Blue	5	Direction
Red	6	N.C.
Violet	7	N.C.
White	8	5V/10-30V
—	9	N.C.
Gray	10	Data
Green	11	Clock
Black	12	0 V Data

12 pin CONIN Connector Part Number: G3 539 202

Bulk Cable (sold by the meter) Part Number: G3 280 220

Cable Assembly (with Connector)

3 meters Part Number: G1 542 003

5 meters Part Number: G1 542 004

10 meters Part Number: G1 542 005

Electrical Connections 8 pin M12

Wire Color	Pin	Function
White	1	5/10-30 Volt
Brown	2	0 Volt
—	3	N.C.
Green	4	Clock
Pink	5	Data
Yellow	6	Clock
Blue	7	Direction
Gray	8	Data

8 pin M12 Connector Part Number: G3 539 597

Bulk Cable (sold by the meter) Part Number: G3 280 251

Cable Assembly (with Connector)

3 meters Part Number: G1 565 329

5 meters Part Number: G1 565 330

10 meters Part Number: G1 565 331