

Series AI25 Profibus Interface

- Up to 14 Bit single-turn resolution
- 4096 revolutions of multi-turn resolution
- Short installation depth
- Safety through self-diagnostics
- Solid shaft and hollow shaft versions
- -40°C to +85°C Operating temperature



ACURO



APPLICATION/INDUSTRY

The Dynapar brand ACURO Absolute Encoder offers a modern full-feature design equipped with Profibus interface.

DESCRIPTION

The **Acuro AI25** optical absolute industrial encoder is available in a single-turn or multi-turn version. The multi-turn design is based on a reliable high-speed gear with optical scanning and the latest generation of OptoASIC technology.

The mechanical concept is based on a double ball bearing design, which is available as a solid-shaft or hollow-shaft version in common shaft diameters.

FEATURES AND BENEFITS

- Compact design to save valuable space
- Low power consumption
- Fast delivery of any model variant
- Additional field-bus and point-to-point interfaces available

SPECIFICATIONS

STANDARD OPERATING CHARACTERISTICS

Single-turn Resolution: 10, 12, 13, 14 Bit
Multi-turn Resolution: 12 bit
Linearity: +/- 1/2 LSB
Absolute Accuracy: ±0.01° mechanical (36 arc-sec.)
Repeatability: ±0.002° mechanical (7.2 arc-sec.)
Code format: Binary

ELECTRICAL

Connection: Bus Cover with spring terminal clamps
Supply voltage: 10-30 VDC
Intrinsic current consumption: 200 mA (ST), 220 mA (MT)
Baud Rate: 12 Mbaud
Interface: Profibus-DP, Encoder Profile
Programmable: According to Class 2
Special Functions: Speed, Acceleration

MECHANICAL

Shaft diameter:
 Shaft: 6 mm (Servo Mount), 10 mm (Clamping Mount), 3/8" (Square Flange Mount)
 Hubshaft: 10mm, 12 mm, 3/8", 1/2"
Maximum shaft load:
 6 mm shaft: 13 lb axial, 24 lb radial
 10 mm shaft: 24 lb axial, 35 lb radial
Maximum shaft speed: 10,000 RPM (continuous), 12,000 RPM (peak)
Starting torque: < 1.4 in-oz
Weight (approx.): 350 g ST, 400 g MT
Shaft tolerance (hubshaft only): +/- 1.5 mm axial, +/- 0.2 mm radial
Flange configurations: Square, Clamp, Servo, Hubshaft with flexible tether
Bearing life:
 1 x 10¹⁰ revolutions at 35% full rated shaft load
 1 x 10⁹ revolutions at 75% full rated shaft load
 1 x 10⁸ revolutions at 100% full rated shaft load

ENVIRONMENTAL

Operating Temperature: -40 to 85° C
Storage Temperature: -40 to 100° C
Enclosure Rating: IP64 or IP67
Shock: 1,000 m/s² (6 ms)
Vibration: 100 m/s² (10 to 2,000 Hz)

Code 1: Model	Code 2: Bits	Code 3 :Mounting	Code 4: Shaft Size	Code 5: Protocol	Code 6: Electrical	Code 7: Connector
AI25	<input type="checkbox"/> <input type="checkbox"/> <input type="checkbox"/> <input type="checkbox"/>	<input type="checkbox"/>	<input type="checkbox"/>	<input type="checkbox"/>	<input type="checkbox"/>	<input type="checkbox"/>
AI25 Size25 Acuro Absolute Encoder	Single-Turn	Available when Code 4 is 0 or A	w/o shaft seal (IP64) 0 6 mm 1 3/8" 2 10 mm 3 3/8" Hub Shaft 4 12 mm Hubshaft 5 1/2" Hubshaft 6 10 mm Hub Shaft	6 Profibus	2 10-30 VDC	E Bus Cover 3 Strain Relief Exits. Internal T-coupler included
	0010 10 Bit	0 Servo*				
	0012 12 Bit	Available when Code 4 is 2 or C				
	0013 13 Bit	1 Clamping*				
	0014 14 Bit	Available when Code 4 is 1 or B				
	Multi-Turn	2 Square flange**				
	1212 12 Bit Multi-Turn, 12 Bit Single-Turn	Available when Code 4 is 3, 4, 5 or 6	w/ shaft seal (IP67) A 6 mm B 3/8" C 10 mm			
	1213 12 Bit Multi-Turn, 13 Bit Single-Turn	3 Hubshaft w/tether†				
	1214 12 Bit Multi-Turn, 14 Bit Single-Turn	* 58mm Dia. ** 2.5" Square † 63mm BC				

Series AI25 Profibus Interface

Code 3: Mounting

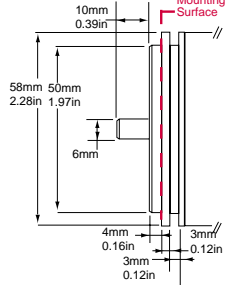
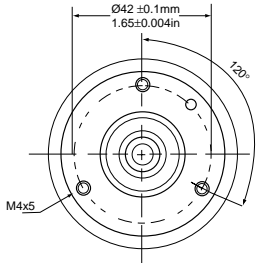

0
Servo

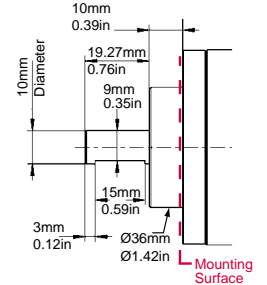
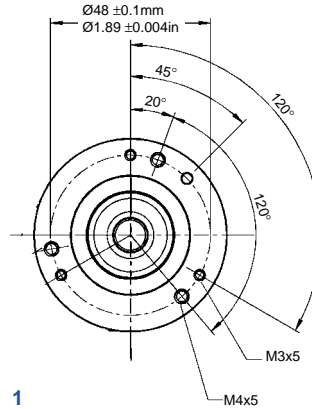

1
Clamping

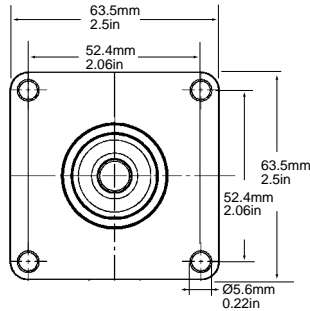
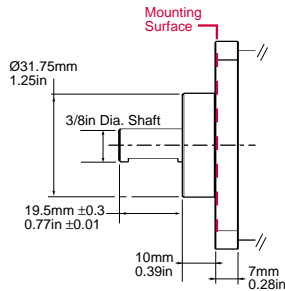

2
Square Flange

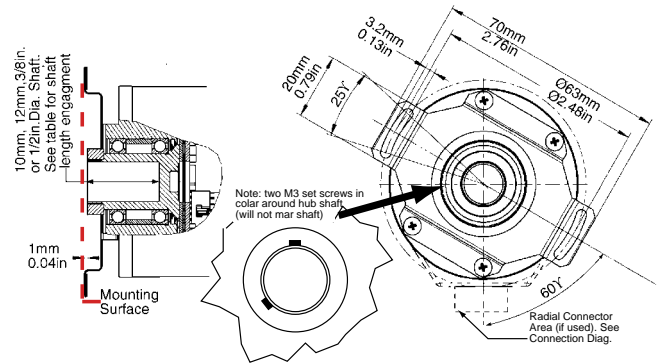

HubShaft Diameter	Min. Shaft Length	Max. Shaft Length
10mm, 3/8"	15mm (0.59")	20mm (0.79")
12mm, 1/2"	18mm (0.71")	20mm (0.79")

3
Hubshaft w/Tether

Code 7: Connector

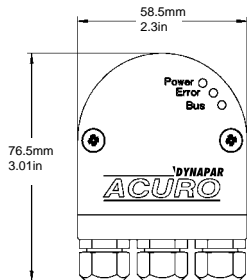
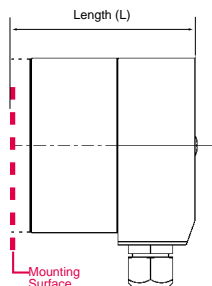

E

3 Strain Relief Exits

Length (L) Mounting Surface to Rear
For connector types E, G, H & L

Mount (Code 3)	Single-Turn	Multi-Turn
(0) Servo	63.3/2.49	72.3/2.85
(1) Clamping	62.3/2.45	71.3/2.81
(2) Square Flng	64.8/2.55	73.8/2.91
(3) Hubshaft	72.2/2.84	81.2/3.2

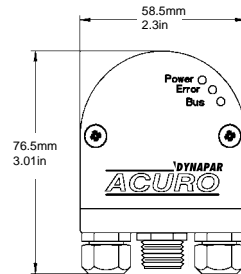
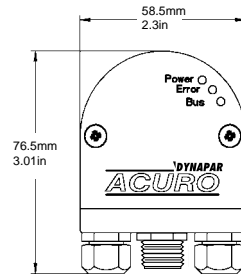

G

2 Strain Relief Exits
1 M12, 5-pole Connector*

*M12, 5-pole Connector used to interface Hengstler Tico 731 LCD display

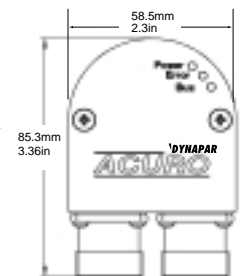
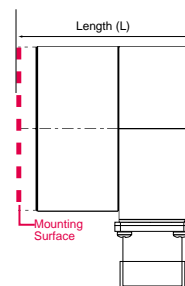

H

Double Conin