

# Series AI25 Parallel Interface

- Up to 14 Bit single-turn resolution
- 4096 revolution multi-turn resolution
- Short installation depth
- Safety through self-diagnostics
- Solid shaft and hollow shaft versions
- -40°C to +100°C Operating temperature



**ACURO**



## APPLICATION/INDUSTRY

The Dynapar brand ACURO Absolute Encoder offers a modern full-feature design equipped with Parallel interface.

## DESCRIPTION

The Acuro AI25 optical absolute industrial encoder is available in a single-turn or multi-turn version. The multi-turn design is based on a reliable high-speed gear with optical scanning and the latest generation of OptoASIC technology.

The mechanical concept is based on a double ball bearing design, which is available as a solid-shaft or hollow-shaft version in common shaft diameters.

## FEATURES AND BENEFITS

- Compact design to save valuable space
- Low power consumption
- Fast delivery of any model variant
- Additional field-bus and point-to-point interfaces available

## SPECIFICATIONS

### STANDARD OPERATING CHARACTERISTICS

**Single-turn Resolution:** 10, 12, 13, 14 Bit, 360 PPR, 720 PPR

**Multi-turn Resolution:** 12 bit (only available with 12 bit ST resolution)

**Absolute Accuracy:** ±0.01° mechanical (36 arc-sec.)

**Repeatability:** ±0.002° mechanical (7.2 arc-sec.)

**Code format:** Binary, Gray, Gray Excess

### ELECTRICAL

**Connection:** Cable, Conin Connector, MS Connector, Cable with Sub-D Connector (MT only)

**Supply voltage:** 5 VDC -5%/+10%, or 10-30 VDC

**Intrinsic current consumption:** 200 mA (ST), 300 mA (MT)

**Output current:** 30 mA per bit, short circuit protected

**Frequency response:** 500 kHz on single-turn, 1.5m cable\*

**Alarm output:** NPN open collector max 5 mA

**Maximum cable length:** 100 m

\*Data refresh rate: 70µsec is for multi-turn and single-turn with preset

**Status LED:** Green = OK, Red = Alarm (IP64 only, not available on connector type J)

**Preset Switch:** Sets encoder to zero output at present mechanical position (Multi-turn IP64 only, not available on connector type J)

**Control Inputs:** Latch, Direction, Tri-state (see table below)

### MECHANICAL

**Shaft diameter:**

Shaft: 6 mm (Servo Mount), 10 mm (Clamping Mount), 3/8" (Square Flange Mount)

Hubshaft: 10mm, 12 mm, 3/8", 1/2"

**Maximum shaft load:**

6 mm shaft: 13 lb axial, 24 lb radial

10 mm shaft: 24 lb axial, 35 lb radial

**Maximum shaft speed:** 10,000 RPM (continuous), 12,000 RPM (peak)

**Starting torque:** < 1.4 in-oz

**Weight (approx.):** 350 g ST, 400 g MT

**Shaft tolerance (hubshaft only):** +/- 1.5 mm axial, +/- 0.2 mm radial

**Flange configurations:** Square, Clamp, Servo, Hubshaft with flexible tether

**Bearing life:**

1 x 10<sup>10</sup> revolutions at 35% full rated shaft load

1 x 10<sup>9</sup> revolutions at 75% full rated shaft load

1 x 10<sup>8</sup> revolutions at 100% full rated shaft load

### ENVIRONMENTAL

**Operating Temperature:** -40 to 100° C

**Storage Temperature:** -40 to 100° C

**Enclosure Rating:** IP64 or IP67

**Shock:** 1,000 m/s<sup>2</sup> (6 ms)

**Vibration:** 100 m/s<sup>2</sup> (10 to 2,000 Hz)

Control Inputs		
Input	Logic Level	Function
Direction	1	Ascending code values when turning clockwise
	0	Descending code values when turning clockwise
Latch	1	Encoder data continuously changing at output
	0	Encoder data stored and constant at output
Tristate (ST)	1	Outputs active
	0	Outputs at high impedance (Tristate mode)
Tristate (MT)	1	Outputs at high impedance (Tristate mode)
	0	Outputs active

Code 1: Model	Code 2: Bits	Code 3 :Mounting	Code 4: Shaft Size	Code 5: Protocol	Code 6: Electrical	Code 7: Connector
<b>AI25</b>	□□□□	□	□	□	□	□
<b>AI25</b> Size25 Acuro Absolute Encoder	<b>Single-Turn</b> 0010 10 Bit 0012 12 Bit 0013 13 Bit 0014 14 Bit 0360 360 PPR (Gray excess) 0720 720 PPR (Gray excess)  Available when Code 6 is 2 <b>Multi-Turn</b> 1212 12 Bit Multi-Turn, 12 Bit Single-Turn	Available when Code 4 is 0 or A 0 Servo*  Available when Code 4 is 2 or C 1 Clamping*  Available when Code 4 is 1 or B 2 Square flange**  Available when Code 4 is 3, 4, 5 or 6 3 Hubshaft w/tether† * 58mm Dia. ** 2.5" Square † 63mm BC	<b>w/o shaft seal (IP64)</b> 0 6 mm 1 3/8" 2 10 mm 3 3/8" Hub Shaft 4 12 mm Hubshaft 5 1/2" Hubshaft 6 10 mm Hub Shaft  <b>w/ shaft seal (IP67)</b> A 6 mm B 3/8" C 10 mm	0 Parallel Binary  1 Parallel Gray	0 5 VDC 2 10-30 VDC	0 1.5m axial cable 1 1.5m radial cable  Available when Code 2 is 00XX, 0360 or 0720 6 M23 Conin 17 pin axial CW 7 M23 Conin 17 pin radial CW J 17 pin MS axial * K 19 pin Bayonet radial  Available when Code 2 is 1212 A Cable 1.5m radial w/ 37 pin sub-D B Cable 1.5m axial w/37 pin sub-D  * Status LED and Preset Switch features not available with 'J'

Code 3: Mounting

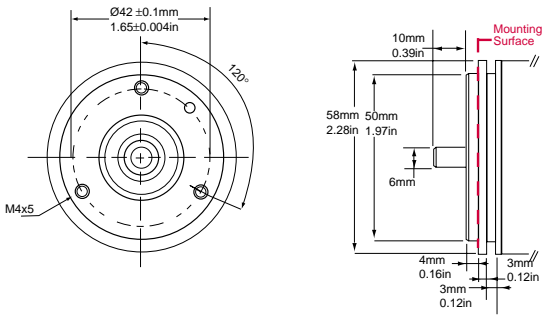

**0**  
Servo

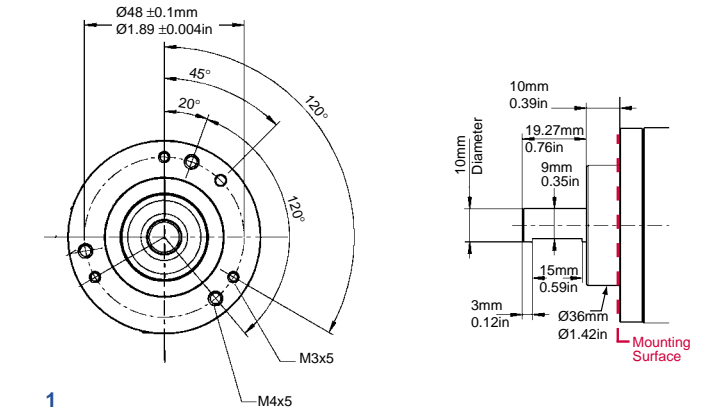

**1**  
Clamping

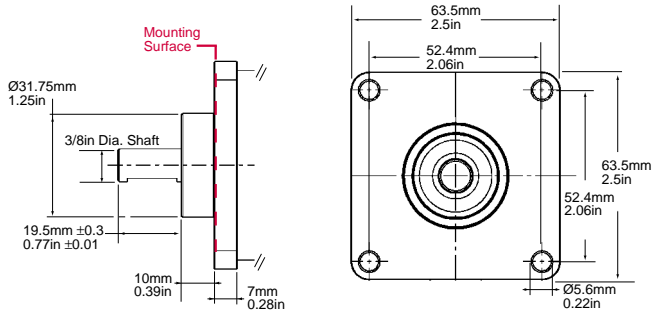

**2**  
Square Flange

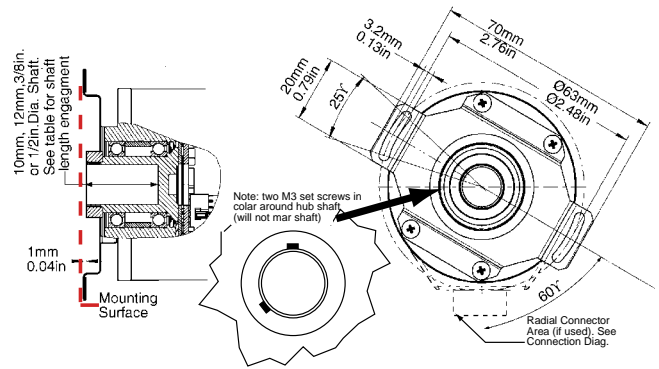

**3**  
Hubshaft w/Tether

**Hubshaft Shaft Engagement**

HubShaft Diameter	Min. Shaft Length	Max. Shaft Length
10mm, 3/8"	15mm (0.59")	20mm (0.79")
12mm, 1/2"	18mm (0.71")	20mm (0.79")

Code 7: Connector

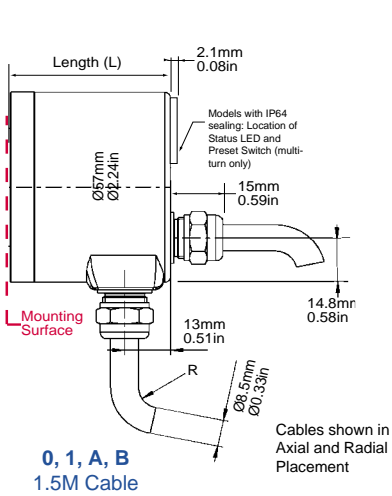

**0, 1, A, B**  
1.5M Cable

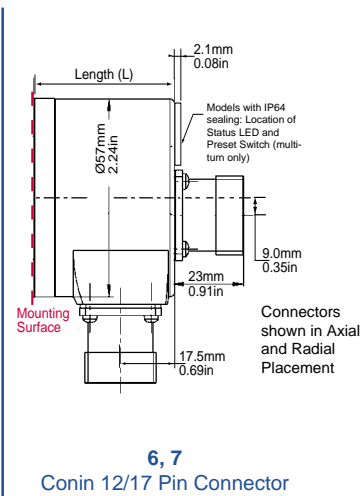

**6, 7**  
Conin 12/17 Pin Connector

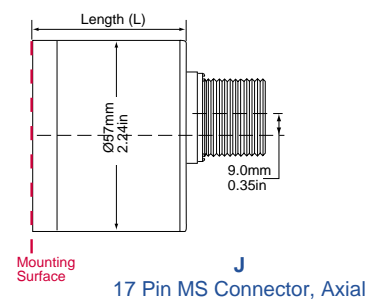

**J**  
17 Pin MS Connector, Axial

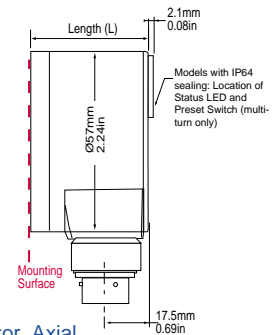

**K**  
19 Pin Bayonet Connector, Axial

Length (L) Mounting Surface to Rear

Mount (Code 3)	Single-Turn	Multi-Turn
(0) Servo	46.5/1.83	60.2/2.37
(1) Clamping	45.5/1.79	59.2/2.33
(2) Square Flng	45.5/1.79	59.2/2.33
(3) Hubshaft	49.9/1.96	67.1/2.64

ABSOLUTE

**CONNECTOR WIRING**

# Series AI25 Parallel Interface

Explanation of Terms		
Tristate	+UB = Outputs at high impedance (Tristate mode) 0 V <sup>2)</sup> = Outputs active	
Tristate	+UB <sup>2)</sup> = Outputs active 0 V = Outputs at high impedance (Tristate-Mode)	
Latch	+UB <sup>2)</sup> = Encoder data continuously changing at output 0 V = Encoder data stored and constant at output	
Direction	+UB <sup>2)</sup> = Ascending code value when turning cw 0 V = Descending code value when turning cw	
N.C.	= Not Connected	
LSB	= Least Significant Bit	
MSB	= Most Significant Bit	
S0, S1, ...	= Data bits for resolution per turn	
M0, M1, ... (Multiturn)	= Data bits for number of turns	

2) Or unattached (floating)

PVC-cable (Singleturn) 9-12 Bit			
Color	9 Bit / 360 <sup>3)</sup>	10 Bit/720 <sup>3)</sup>	12 Bit
brn/gry	N.C.	N.C.	S0 (LSB)
red/blu	N.C.	N.C.	S1
vio	N.C.	S0 (LSB)	S2
wht/brn	S0 (LSB)	S1	S3
wht/grn	S1	S2	S4
wht/yel	S2	S3	S5
wht/gry	S3	S4	S6
wht/pnk	S4	S5	S7
wht/blu	S5	S6	S8
wht/red	S6	S7	S9
wht/blk	S7	S8	S10
brn/grn	S8 (MSB)	S9 (MSB)	S11 (MSB)
yel	Tristate D0...D8	Tristate D0...D9	Tristate D0.. D11
pnk	Latch <sup>4)</sup>	Latch <sup>4)</sup>	Latch <sup>4)</sup>
grn	Direction	Direction	Direction
blk	0 V	0 V	0 V
red	5/10...30VDC	5/10...30VDC	5/10...30VDC
brn	Alarm	Alarm	Alarm

3) Increments 4) Binary Only

Connector 17pol. (CONIN) 9-12 Bit			
Pin	9 Bit / 360 <sup>3)</sup>	10 Bit / 720 <sup>3)</sup>	12 Bit
1	S0 (LSB)	S0 (LSB)	S0 (LSB)
2	S1	S1	S1
3	S2	S2	S2
4	S3	S3	S3
5	S4	S4	S4
6	S5	S5	S5
7	S6	S6	S6
8	S7	S7	S7
9	S8 (MSB)	S8	S8
10	N.C.	S9 (MSB)	S9
11	N.C.	N.C.	S10
12	Tristate S0...S8	Tristate S0...S9	S11 (MSB)
13	Latch <sup>4)</sup>	Latch <sup>4)</sup>	Latch <sup>4)</sup>
14	Direction	Direction	Direction
15	0 V	0 V	0 V
16	5/10...30VDC	5/10...30VDC	5/10...30VDC
17	Alarm	Alarm	Alarm

3) Increments 4) Binary Only

Connector 17pol. (CONIN) 13-14 Bit		
Pin	13 Bit	14 Bit
1	S12 (MSB)	S13 (MSB)
2	S11	S12
3	S10	S11
4	S9	S10
5	S8	S9
6	S7	S8
7	S6	S7
8	S5	S6
9	S4	S5
10	S3	S4
11	S2	S3
12	S1	S2
13	S0 (LSB)	S1
14	Direction	S0 (LSB)
15	0 V	0 V
16	5/10...30VDC	5/10...30VDC
17	Latch (Binarycode) Alarm (Graycode)	Latch (Binarycode) Alarm (Graycode)

TPE-cable (Multiturn 13-14 Bit) 37 pol. Sub-D		
Color	Pin	
brn	2	S0
grn	21	S1
yel	3	S2
gry	22	S3
pnk	4	S4
vio	23	S5
gry/pnk	5	S6
red/blu	24	S7
wht/grn	6	S8
brn/grn	25	S9
wht/yel	7	S10
yel/brn	26	S11
wht/gry	8	M0
gry/brn	27	M1
wht/pnk	9	M2
pnk/brn	28	M3
wht/blu	14	M4
brn/blu	33	M5
wht/red	15	M6
brn/red	34	M7
wht/blk	16	M8
brn/blk	35	M9
gry/grn	17	M10
yel/gry	36	M11
pnk/grn	18	Alarm
yel/pnk	10	Direction
grn/blu	30	Latch
yel/blu	12	Tristate
red	13	10...30 VDC
wht	31	10...30 VDC
blu	1	0 V
blk	20	0 V

MS style 17 pin connectors					
Pin	Function		107865 Cable Accessory* Color Code	14 BIT	13 BIT
	12 Bit 4096 CPR	10 Bit 1024 CPR			
A	Vin		Red	D13 (MSB)	D12 (MSB)
B	N.C.		Violet	D12	D11
C	Latch (binary only)		Green	D11	D10
D	Direction		Orange	D10	D9
E	S1	N.C.	White	D9	D8
F	S3	S1	White/Brown	D8	D7
G	S5	S3	White/Orange	D7	D6
H	S7	S5	White/Green	D6	D5
J	S8	S6	White/Blue	D5	D4
K	S9	S7	White/Violet	D4	D3
L	S11 (MSB)	S9 (MSB)	White/Black/Brown	D3	D2
M	GND		Black	D2	D1
N	S4	S2	White/Red	D1	D0 (LSB)
P	S0 (LSB)	N.C.	Gray	D0 (LSB)	Direction
R	S2	S0 (LSB)	White/Black	GND	GND
S	S6	S4	White/Yellow	Latch	Latch
T	S10	S8	White/Grey	Vin	Vin
10ft Cable # 107865-0010				NA	
Mating Connector: MS 17 pin style MS3106A-20-29S part # MCN-N8					
*This is a mating connector/cable assembly. Color coding information is provided here for reference					

PVC-cable (Singleturn 13-14 Bit)		
Color	13 Bit	14 Bit
<b>gry/pnk</b>	N.C	S0 (LSB)
<b>brn/yel</b>	S0 (LSB)	S1
<b>brn/gry</b>	S1	S2
<b>red/blu</b>	S2	S3
<b>vio</b>	S3	S4
<b>wht/brn</b>	S4	S5
<b>wht/grn</b>	S5	S6
<b>wht/yel</b>	S6	S7
<b>wht/gry</b>	S7	S8
<b>wht/pnk</b>	S8	S9
<b>wht/blu</b>	S9	S10
<b>wht/red</b>	S10	S11
<b>wht/blk</b>	S11	S12
<b>brn/grn</b>	S12 (MSB)	S13 (MSB)
<b>yel</b>	Tristate S0...S12	Tristate S0...S13
<b>pnk</b>	Latch <sup>4)</sup>	Latch <sup>4)</sup>
<b>grn</b>	Direction	Direction
<b>blk</b>	0 V	0 V
<b>red</b>	5/10...30VDC	5/10...30VDC
<b>brn</b>	Alarm	Alarm

4) Binary Only

Bayonet style 19 pin connectors							
Pin	Function 14 Bit 16384 CPR	112077 Cable Accessory* Color Code	Function 13 bit 8192 CPR	112076 Cable Accessory* Color Code	Function		110158 Cable Accessory* Color Code
					12 Bit 4096 CPR	10 Bit 1024 CPR	
A	S13 (MSB)	White/Black/Brown	S12	White/Black/Brown	S11 (MSB)	S9 (MSB)	White/Black/Brown
B	S12	White/Grey	S11	White/Grey	S10	S8	White/Grey
C	S11	White/Violet	S10	White/Violet	S9	S7	White/Violet
D	S10	White/Blue	S9	White/Blue	S8	S6	White/Blue
E	S9	White/Green	S8	White/Green	S7	S5	White/Green
F	S8	White/Orange	S7	White/Orange	S6	S4	White/Orange
G	S7	White/Yellow	S6	White/Yellow	S5	S3	White/Yellow
H	S6	White/Red	S5	White/Red	S4	S2	White/Red
J	S5	White/Brown	S4	White/Brown	S3	S1	White/Brown
K	S4	White/Black	S3	White/Black	S2	S0 (LSB)	White/Black
L	S3	Brown	S2	Blue	S1	N.C.	White
M	S2	Blue	S1	White	S0 (LSB)	N.C.	Grey
N	S1	White	S0 (LSB)	Grey	N.C.	N.C.	
P	S0 (LSB)	Grey	GND	Black	GND		Black
R	Direction	Orange	Direction	Orange	Direction		Orange
S	Case	Violet	Case	Violet	Case		Violet
T	GND	Black	GND	Yellow	GND		Yellow
U	Latch	Green	Latch	Green	Latch (binary only)		Green
V	Vin	Red	Vin	Red	Vin		Red
10ft Cable # 112077-0010		10ft Cable # 112076-0010			10ft Cable # 110158-0010		
Mating Connector: 19 pin Bayonet style PT06E-14-19S part # 606219-0001							

\*This is a mating connector/cable assembly. Color coding information is provided here for reference