

SLIM Tach SL1250



- Mounts to NEMA 12.5 inch C face motor
- Thin, compact, and occupies only 1.4 inches of motor shaft
- Rugged, reliable, magnetoresistive technology
- Easy installation with no brackets or couplings
- Hard, anodized aluminum construction

APPLICATION/INDUSTRY

NorthStar's SLIM Tach 1250 is an economical, bearingless, heavy duty encoder designed for 12.5 inch C face motors. Available with resolutions to 1024 PPR.

DESCRIPTION

Employing NorthStar's innovative magnetoresistive technology, this dependable product combines high accuracy with reliable service. Made of anodized aluminum and with a net thickness of only 1.4 inches, the SL1250 comes with one or two electrically independent and totally isolated output modules and a high temperature version for operation needs up to 120° C.

The SLIM Tach 1250 assembly is imprinted with magnetic poles, providing higher pulse counts than traditional encoders. Its totally encapsulated electronics make it immune to machine vibration and contaminants. It is resistant to dirt, grease, water, oil, fibers, and dust, making it reliable in hot, wet environments. A high power line driver comes standard. Clean, crisp signals are ensured over long cable lengths, decreasing the need for signal repeaters and saving on total installation costs.

The SLIM Tach 1250's pulse wheels are available in thru-shaft sizes from 0.625 inch to 3.75 inches. The pulse wheels are keyless and very easy to align. The SL1250's thin profile leaves plenty of room on the motor shaft for a brake or pulley and it mounts without bearings, adapter plates, or couplings, eliminating a common source of mechanical problems.

FEATURES AND BENEFITS

- Thru-shaft sizes from 0.625 to 3.75 inches
- 64, 128, 256, 512, or 1024 pulses per revolution (PPR) with optional index pulse
- 5-15VDC operation, bi-directional quadrature signals with high power, differential line driver outputs

SPECIFICATIONS

STANDARD OPERATING CHARACTERISTICS

Code: Incremental
Pulses per Revolution: 64-1024
Phasing Sense: A leads B for Counter-Clockwise rotation (CCW) viewing encoder-mounted end
Quadrature Phasing: 90° ± 22°
Symmetry: 180° ± 54°
Index: 270° gated to falling B edge

ELECTRICAL

Input Voltage Requirement: 5-15 or 5-26 Volts DC
Current Requirement:
 With Electrical Option L or H: 45 mA typical per sensor module plus line driver load
 With Electrical Option V or 5: 65 mA typical per sensor module plus line driver load
Output Signals:
 With Elec Option L or H: 5-15 V Line Driver, 150mA
 With Elec Option V: 5-26 V Line Driver, 100mA
 With Elec Option 5: 5V Line Driver, 150mA
Frequency Response: 0 - 120kHz Data & Index
Electrical Immunity: 2kV ESD, Reverse Polarity, Short Circuit

ELECTRICAL CONNECTIONS

Connector: 10 pin industrial duty latching, sealed NEMA 4 & 12, IP65; MS connector or pig-tail

Signal	Connector Pin	Pigtail Cable	MS 3102E18-IT#
Common	1	Black	F
B	2	Green	B
A	3	Blue	A
Z *	4	Violet	C
No Connection	5	—	E
Vcc (5-15 VDC)	6	Red	D
B̄	7	Yellow	I
Ā	8	Gray	H
Z *	9	Orange	J
Shield	10	Braid	G

* Index (Z) optional. See Ordering Information

MECHANICAL

Shaft Speed: 7,000 RPM
Mounting Configuration: 12.5" C face mount for NEMA MG1-4 standards (excluding C-Face runout)
Housing Material: Cast Aluminum
Acceleration Rate: 12,000 rpm/sec max
Shaft Length Required: 1.1" min
Allowable Shaft End-Play: ± 0.045"
Allowable Shaft Runout: 0.003" TIR
Weight: 11 lbs.

ENVIRONMENTAL

Operating Temperature Range:
 Standard: -40°C to +90°C
 Extended: -40°C to +120°C
Storage Temperature Range: -40°C to +120°C
Humidity: to 98% RH (non-condensing)
Shock (Sensor Module): 1 meter drop test, 30 G's Min
Vibration: 18 G's @ 5-2000 Hz spectrum

DIMENSIONS
inches [mm]

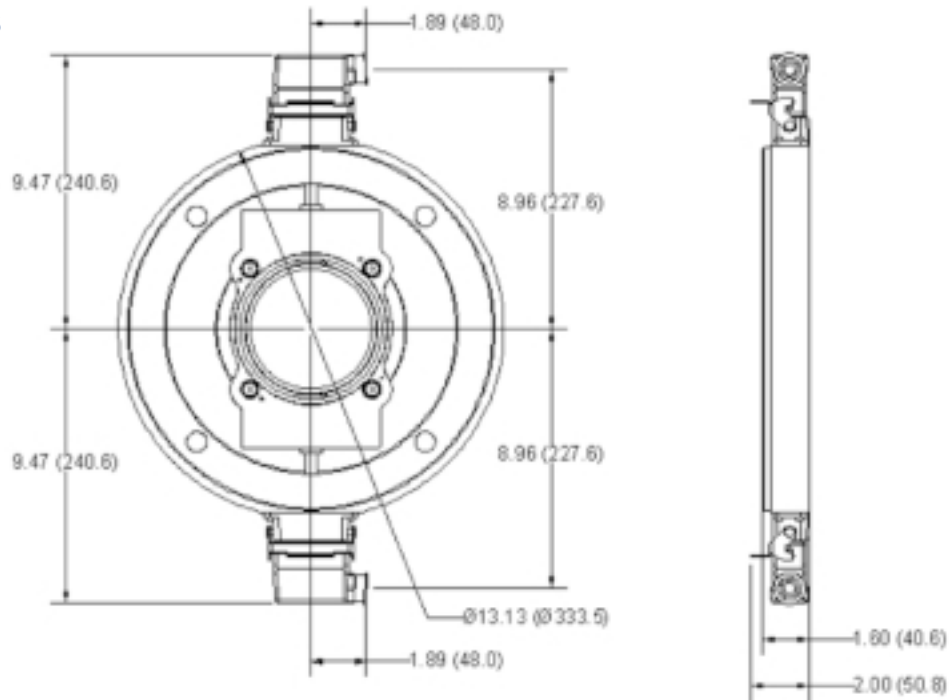

ORDERING INFORMATION

Code 1: Model	Code 2: PPR	Code 3: Index	Code 4: Wheel Bore	Code 5: Termination	Code 6: Electrical	Code 7: Cover/Adapter
□ 1	□□□□	□	□□□	□	□	□
Ordering Information						
S1 Motor Mount Ring, for 12 1/2" NEMA C-Face Motors Single Output	0064 0128 0256 0512 1024	L No Index Available when Code 2 is 0512 or 1024 Z Differential Index (Z, Z)	J04 5/8" bore J05 7/8" bore J06 1.00" bore J07 1-1/8" bore K09 1-3/8" bore K10 1-1/2" bore K11 1-5/8" bore K12 1-3/4" bore K13 1-7/8" bore K14 2.00" bore K15 2-1/8" bore K16 2-1/4" bore K17 2-3/8" bore K18 2-1/2" bore K19 2-7/8" bore Additional Shaft Sizes Available Up to 3.75" Maximum	C Latching Industrial Connector with 1/2" NPT M 10 pin MS Connector P 18" pigtail cable Q Latching Industrial Connector on 18" pigtail cable	L 5-15V in, 5-15V Line Driver (4428) out H Same as L with extended temp. to 120°C V 5-26V in, 5-26V Line Driver (IC-WE) out 5 5-15V in, 5V Line Driver (4428) out Differential, bidirectional signals (A, \bar{A} , B, \bar{B})	C Standard Cover F Flat Thru-hole cover
D1 Motor Mount Ring, for 12 1/2" NEMA C-Face Motors Dual Output						

HEAVY DUTY

Spare Pulse Wheel: Use "NS" followed by Code 2 (PPR) & Code 3 (Index) & Code 4 (Bore Size). Example: NS0512ZK11

Spare Mating Connector: Use "NS" followed by Code 1 (Model) & Code 5 (Termination). Example: NSS1C

Spare Cover: Use "NS" followed by Code 1 (Model) & Code 4 (Bore Size) & Code 7 (Cover). Example: NSS1K11C

5 foot Interface Cable: RIMCABLEDB10005. Other Length: final 4 digits is length in 5 ft increments. Example RIMCABLEDB10065 is 65 feet.