

SLIM Tach RL67

- *Unique mechanical design for Reliance RPM™ motors*
- *Rugged, zero-speed, magneto-resistive sensing technology is unaffected by grease, salt water, dust, and other common contaminants*



APPLICATION/INDUSTRY

The SLIM Tach® RL67 heavy duty encoder is a breakthrough innovation in feedback technology. Incorporating dual mounting features, the RL67 was designed especially for Reliance Electric, Inc. RPM® AC or DC motors.

DESCRIPTION

The hard anodized aluminum alloy frame provides strength, ruggedness, and corrosion resistance. The hardened encapsulated electronics offer outstanding reliability under heavy machine vibration and accidental impacts. The electronics range from +5 to +15 volts DC and include the latest in short circuit proof design on all output pins. High power, complementary, line driver outputs assure clean, crisp signals over long cable lengths. These outputs are compatible with most drives or other input devices. The advanced magneto-resistive sensing technology operates with an unparalleled immunity to grease, oil, salt water, dirt, fibers, and other contaminants. This eliminates the need to seal the encoder.

The compact RL67 adds only 1.5" to the motor length. Designed to maximize the ease of field installation, the RL67 retrofits onto older existing motors as well as new motors. In some cases, it may be necessary to change the accessory stub shaft in the motor. This stub shaft is also available from us.

The RL67 will mount directly in the 6.75" machined accessory recess of the 4.5" accessory flange found on the motor. This unique modular design mounts quickly and easily with no adapter plates, bearings, or flexible couplings. Installation can be completed in minutes, without gap adjustments or special tools. The encoder can be removed then reinstalled just as easily.

FEATURES AND BENEFITS

- Modular, bearingless, low profile "pancake" design adds only 1.5" to motor length
- 5-15 VDC operation with bi-directional quadrature and signals, with high power differential line driver outputs
- 64, 128, 256, 512, 1024 & 2048 pulses per revolution (PPR) with optional Index pulse
- Up to 120°C operational temperature

SPECIFICATIONS

STANDARD OPERATING CHARACTERISTICS

Code: Incremental
Pulses per Revolution: 64-2048
Phasing Sense: A leads B for Counter-Clockwise rotation (CCW) viewing encoder-mounted end
Quadrature Phasing: 90° ± 22°
Symmetry: 180° ± 54°
Index: 270° gated to falling B edge

ELECTRICAL

Input Voltage Requirement: 5-15 or 5-26 Volts DC
Current Requirement:
 With Electrical Option L or H: 45 mA typical per sensor module plus line driver load
 With Electrical Option V or 5: 65 mA typical per sensor module plus line driver load
Output Signals:
 With Elec Option L or H: 5-15 V Line Driver, 150mA
 With Elec Option V: 5-26 V Line Driver, 100mA
 With Elec Option 5: 5V Line Driver, 150mA
Frequency Response: 0 - 120kHz Data & Index
Electrical Immunity: 2kV ESD, Reverse Polarity, Short Circuit
Connector: 10 pin industrial duty latching, sealed NEMA 4 & 12, IP65

MECHANICAL

Shaft Speed: 7,000 RPM
Mounting Configuration: 4.5" diameter, 56 C motor face or accessory flange to meet NEMA MG1-4 standards or mounts directly in the 6.75" machined accessory recess of the 4.5" accessory flange found on Reliance RPM™ motors
Housing Material: Cast Aluminum
Acceleration Rate: 12,000 rpm/sec max
Shaft Length Required: 2.5" min
Allowable Shaft End-Play: ± 0.045"
Allowable Shaft Runout: 0.003" TIR

ENVIRONMENTAL

Operating Temperature Range: -40°C to +90°C
Storage Temperature Range: -40°C to +120°C
Humidity: to 98% RH (non-condensing)
Shock (Sensor Module): 1 meter drop test, 30 G's Min
Vibration: 18 G's @ 5-2000 Hz spectrum

ELECTRICAL CONNECTIONS

Signal	Connector Pin	Pigtail Cable	MS 3102E18-IT#
Common	1	Black	F
B	2	Green	B
A	3	Blue	A
Z *	4	Violet	C
No Connection	5	—	E
Vcc (+ VDC)	6	Red	D
B̄	7	Yellow	I
Ā	8	Gray	H
Z *	9	Orange	J
Shield	10	Braid	G

* Index (Z) optional. See Ordering Information

DIMENSIONS
inches [mm]

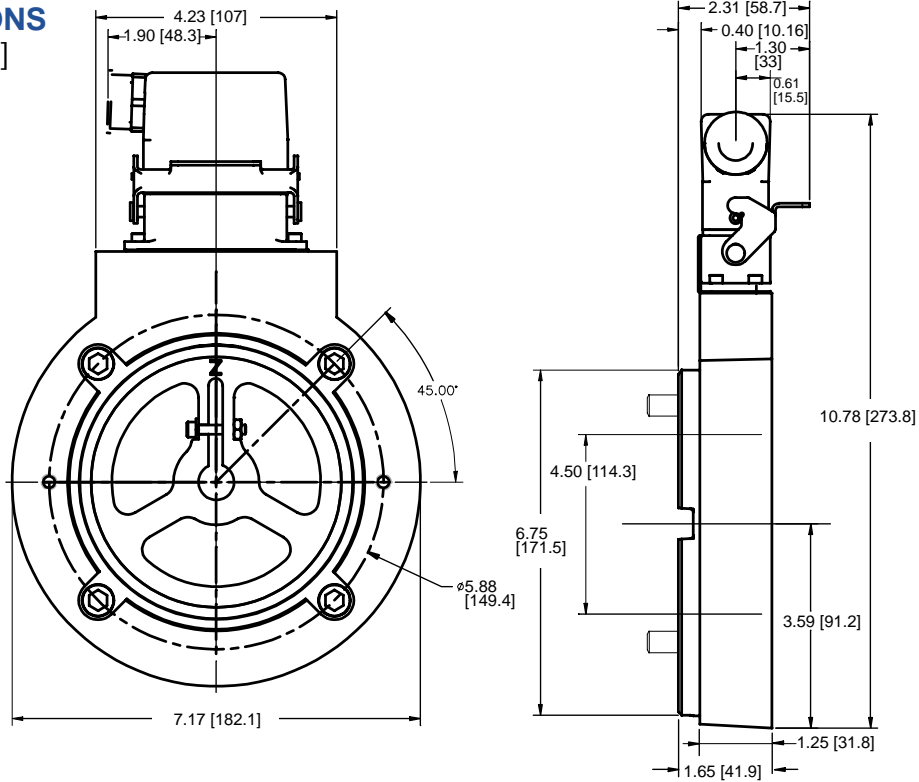

ORDERING INFORMATION

Code 1: Model	Code 2: PPR	Code 3: Index	Code 4: Wheel Bore	Code 5: Termination	Code 6: Electrical	Code 7: Cover
S6	□□□□	□	□□□□	□	□	□
Ordering Information						
S6 Motor Mount Ring, for 4 1/2" NEMA 56-C C-Face Motors or Reliance Electric Style 6.75" Recess	0064 0128 0256 0512 1024 2048	L No Index Available when Code 2 is 0512, 1024 or 2048 Z Differential Index (Z, Z̄)	J04 5/8" bore J05 7/8" bore J06 1.00" bore J07 1-1/8" bore K09 1-3/8" bore K10 1-1/2" bore K11 1-5/8" bore K12 1-3/4" bore K13 1-7/8" bore K14 2.00" bore K15 2-1/8" bore K16 2-1/4" bore K17 2-3/8" bore K18 2-1/2" bore K19 2-7/8" bore Additional Shaft Sizes Available Up to 3.75" Maximum	C Latching Industrial Connector with 1/2" NPT M 10 pin MS Connector P 18" pigtail cable Q Latching Industrial Connector on 18" pigtail cable	L 5-15V in, 5-15V Line Driver (4428) out H Same as L with extended temp. to 120°C V 5-26V in, 5-26V Line Driver (IC-WE) out 5 5-15V in, 5V Line Driver (4428) out Differential, bidirectional signals (A, Ā, B, B̄)	C Standard cover F Flat Thru-hole cover

HEAVY DUTY

Spare Pulse Wheel: Use "NS" followed by Code 2 (PPR) & Code 3 (Index) & Code 4 (Bore Size). Example: NS0512ZK11

Spare Mating Connector: Use "NS" followed by Code 1 (Model) and Code 5 (Termination). Example: NSS6C

Spare Cover: Use "NS" followed by Code 1 (Model) & Code 4 (Bore Size) & Code 7 (Cover). Example: NSS6K11C

5 foot Interface Cable: RIMCABLEDB10005. Other Length: final 4 digits is length in 5 ft increments. Example RIMCABLEDB10065 is 65 feet.