

SLIM Tach HS56 *For Fan Cooled and Non-Motor Applications*



- *Hollow shaft design allows for a variety of possible mountings; ideal to retrofit AC fan cooled motors.*
- *Rugged, zero-speed, magnetoresistive sensing technology is immune to grease, salt water, dust, or other common contaminants.*
- *Up to 80° C operation*

APPLICATION/INDUSTRY

The NorthStar brand HS56 has been designed especially for maintenance, motor repair, and field personnel. It offers an unparalleled means of applying a leading edge digital encoder to motors and other devices that require an innovative method of installation.

DESCRIPTION

The HS56's magnetoresistive sensor technology is virtually immune to common contaminants such as grease, oil, water, and dirt. Hardened encapsulated electronics make it especially resistant to heavy machine vibration and accidental impacts. Advanced electronic design offers many features such as operation from 5-26 volts DC power, short circuit protected outputs, and EMI noise resistance. High power complimentary line driver outputs assure clean, crisp signals over long cable lengths.

A stainless steel and hard anodized aluminum alloy frame provides exceptional strength, ruggedness, and superior corrosion resistance. Its extra heavy duty bearings are designed to maximize its operational life. Since the entire encoder rides on large motor style bearings, the unit can tolerate considerable shaft movement. A strong, insulated, stainless steel anti-rotation arm with multiple mounting holes allows the encoder to move axially, radially, and at a tangent. The simple prealigned design of the HS56 does not require user adjustments.

Easily mounted on fan-cooled motor shafts, conveyor equipment, assembly machines, material feeders, pumps, hydraulic equipment, and gear boxes, the HS56 does not require mounting flanges or accessory brackets. If a suitable shaft is not available, a stub shaft installed through the fan shroud into the motor shaft provides a means of easy mounting.

The HS56 is also available in with electrically isolated dual outputs. Each output can be operated at different voltages and/or sent to different locations. The dual outputs can be used for security with encoder redundancy. A failed output can be quickly switched to the second output, thereby reducing downtime. Our accessory Intellitach™, can continuously monitor the encoder feedback, and automatically switch outputs in the case of signal failure.

FEATURES AND BENEFITS

- Combines rugged reliable feedback with a flexible mounting design. Fits 0.625 - 1.125 inch shaft sizes
- 64, 128, 256, 512, 1024, or 2048 pulses per revolution (PPR) with optional index pulse
- 5-26VDC operation, bi-directional quadrature signals. Short circuit protected, high power line drivers are available

SPECIFICATIONS

STANDARD OPERATING CHARACTERISTICS

Code: Incremental
Pulses per Revolution: 64-2048
Phasing Sense: A leads B for Counter-Clockwise rotation (CCW) viewing encoder-mounted end
Quadrature Phasing: 90° ± 22°
Symmetry: 180° ± 54°
Index: 270° gated to falling B edge

ELECTRICAL

Input Voltage Requirement: 5-15 or 5-26 Volts DC
Current Requirement:
 With Electrical Option L: 45 mA typical per sensor module plus line driver load
 With Electrical Option V or 5: 65 mA typical per sensor module plus line driver load
Output Signals:
 With Elec Option L: 5-15 V Line Driver, 150mA
 With Elec Option V: 5-26 V Line Driver, 100mA
 With Elec Option 5: 5V Line Driver, 150mA
Frequency Response: 0 - 120kHz Data & Index
Electrical Immunity: 2kV ESD, Reverse Polarity, Short Circuit

ELECTRICAL CONNECTIONS

Connector: 10 pin industrial duty latching, sealed NEMA 4 & 12, IP65; MS connector or pig-tail

Signal	Connector Pin	Pigtail Cable	MS 3102E18-IT#
Common	1	Black	F
B	2	Green	B
A	3	Blue	A
Z *	4	Violet	C
No Connection	5	—	E
Vcc +	6	Red	D
B̄	7	Yellow	I
Ā	8	Gray	H
Z̄ *	9	Orange	J
Shield	10	Braid	G

* Index (Z) optional. See Ordering Information

MECHANICAL

Shaft Speed: 3,600 RPM
Mounting Configuration: Hollow Shaft mount with Anti-Rotation Tether
Housing Material: Hard Anodized Aluminum /Stainless Steel
Acceleration Rate: 3,600 rpm/sec max
Shaft Length Required: 2.0" min
Allowable Shaft End-Play: ± 0.150" (tether limit)
Allowable Shaft Runout: 0.015" TIR typical (rpm dependent)

ENVIRONMENTAL

Operating Temperature Range: -20°C to +80°C
Storage Temperature Range: -40°C to +120°C
Humidity: to 98% RH (non-condensing)
Shock (Sensor Module): 1 meter drop test, 30 G's Min
Vibration: 18 G's @ 5-2000 Hz spectrum

DIMENSIONS
inches [mm]

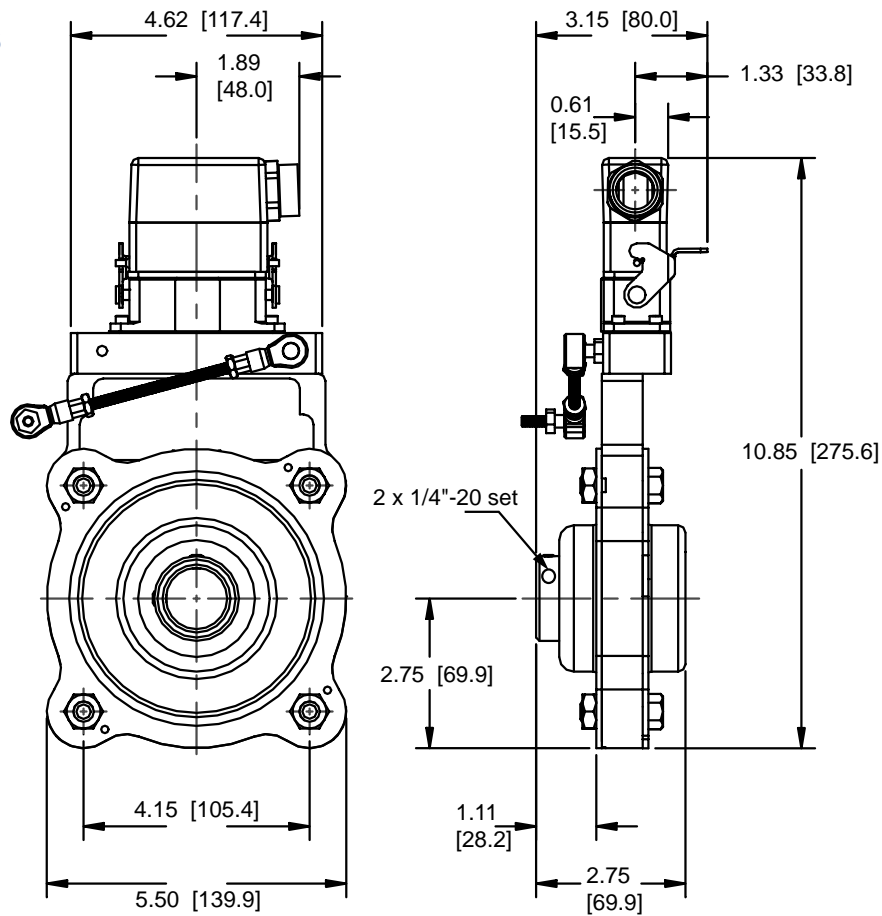

ORDERING INFORMATION

Code 1: Model	Code 2: PPR	Code 3: Index	Code 4: Wheel Bore	Code 5: Termination	Code 6: Electrical
H □	□□□□	□	□□□	□	□
Ordering Information					
H5 Hollow Shaft Mount	0064 0128 0256 0512	L No Index Available when Code 2 is 0512, 1024 or 2048	J04 5/8" bore J05 7/8" bore J06 1.00" bore J07 1-1/8" bore	C Latching Industrial Connector with 1/2" NPT M 10 pin MS Connector P 18" pigtail cable Q Latching Industrial Connector on 18" pigtail cable	L 5-15V in, 5-15V Line Driver (4428) out V 5-26V in, 5-26V Line Driver (1C-WE) out 5 5-15V in, 5V Line Driver (4428) out Differential, bidirectional signals (A, \bar{A} , B, \bar{B})
HD Hollow Shaft Mount Dual Output	1024 2048	Z Differential Index (Z, \bar{Z})			

Spare Mating Connector: Use "NS" followed by Code 1 (Model) and Code 5 (Termination). Example: NSH5C
5 foot Interface Cable: RIMCABLEDB10005. Other Length: final 4 digits is length in 5 ft increments. Example RIMCABLEDB10065 is 65 feet.

HEAVY DUTY