

RIM Tach 8500

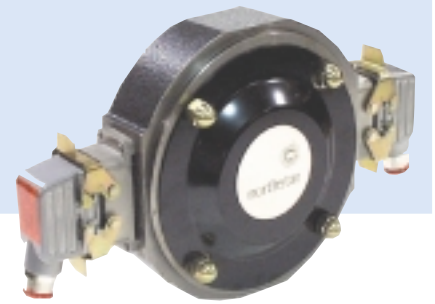

- High performance feedback for AC and DC drive control systems
- Thin, pancake style design mounts to motor without bearings or couplings
- Rugged, zero speed, magnetoresistive sensing technology is unaffected by grease, salt water, dust or other contaminants
- Highly reliable speed signals for mill duty applications
- Stainless steel and cast iron construction
- Resolution to 1200 pulses per revolution

APPLICATION/INDUSTRY

The ©NorthStar brand RIM Tach® 8500 is a mill duty digital tachometer which provides precise, reliable speed signals for even the most difficult mill processes.

DESCRIPTION

The 8500 is the most reliable magnetoresistive digital tachometer found on the market today. Available in either thru-shaft or end-of shaft models, it is specifically designed to provide feedback for AC and DC drive control systems.

Its ductile cast iron enclosure ensures rugged and reliable performance in the harshest environments. Its bearingless design greatly reduces failures and loading on the system. The 8500 features a magnetized drum that accommodates large (up to 4.5") thru-shaft or end-of-shaft mounting.

The 8500 accepts one or two stainless steel sensor modules with patented magneto-resistive technology. Each module generates A and B signals in quadrature, an optional index pulse Z, and each of their complements (A, B, Z). These reliable sensor modules can utilize DC power from +5 to +15 volts, provide transient and noise suppression, and reverse polarity protection. The 8500 high performance tachometer provides resolutions up to 1200 pulses per revolution, which is much higher than traditional encoders.

Its standard mill duty latching connectors are very easy to wire by simply inserting the stripped conductors into the plug and tightening the screw terminals. There is no need to field solder or to struggle with crimp pins. The unit easily mounts on a standard NEMA180 C face (8.5") and requires no gap adjustments. The sensor module is very simple to change, just remove four screws and slide the new sensor module in place. Finally, an optional shaft grounding brush can be added to the unit to reduce or eliminate motor shaft currents, thereby increasing motor bearing life.

FEATURES AND BENEFITS

- Rugged Mill Duty Construction
- Reliable Magnetoresistive Technology
- Easy Installation

SPECIFICATIONS

STANDARD OPERATING CHARACTERISTICS

Code: Incremental
Pulses per Revolution: 60-1200
Phasing Sense: A leads B for Counter-Clockwise rotation (CCW) viewing encoder-mounted end
Quadrature Phasing: 90° ± 22°
Symmetry: 180° ± 54°
Index: 270° gated to falling B edge

ELECTRICAL

Input Power Requirements: 5-15 Volts DC, 45 mA typical per sensor module plus line driver load
Output Signals: Line Driver, 150mA source/sink
Frequency Response: 0 - 120kHz Data & Index
Electrical Immunity: 2kV ESD, Reverse Polarity, Short Circuit
Connector: 10 pin industrial duty latching, sealed NEMA 4 & 12, IP65

ELECTRICAL CONNECTIONS

Signal	Connector Pin	Pigtail Cable	MS 3102E18-IT#
Common	1	Black	A
B	2	Green	E
A	3	Blue	D
Z *	4	Violet	C
No Connection	5	—	—
Vcc (5-15 VDC)	6	Red	B
\bar{B}	7	Yellow	H
\bar{A}	8	Gray	G
\bar{Z} *	9	Orange	I
Shield	10	Braid	J

* Index (Z) optional. See Ordering Information

MECHANICAL

Shaft Speed: 7,000 RPM
Mounting Configuration: 8.5" 180C face mount for NEMA MG1 standards
Housing Material: Cast Iron/Stainless Steel
Acceleration Rate: 3600 rpm/sec max
Shaft Length Required: 2.5" min
Allowable Shaft End-Play: ± 0.050"
Allowable Shaft Runout: 0.003" TIR

ENVIRONMENTAL

Operating Temperature Range: -40°C to +80°C
Storage Temperature Range: -40°C to +120°C
Humidity: to 98% RH (non-condensing)
Shock (Sensor Module): 1 meter drop test, 30 G's Min
Vibration: 18 G's @ 5-2000 Hz spectrum

DIMENSIONS

inches [mm]

(4) 1/2"-13UNC
X 3.47 STUDS

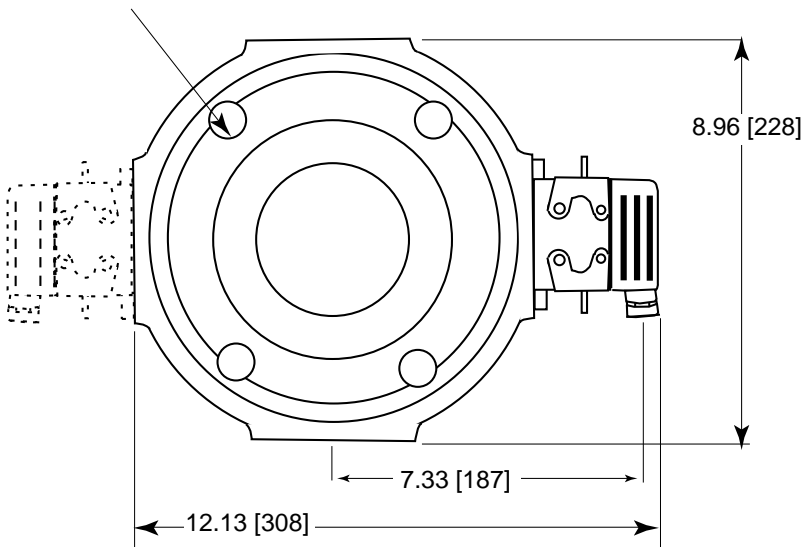

RIM Tach 8500

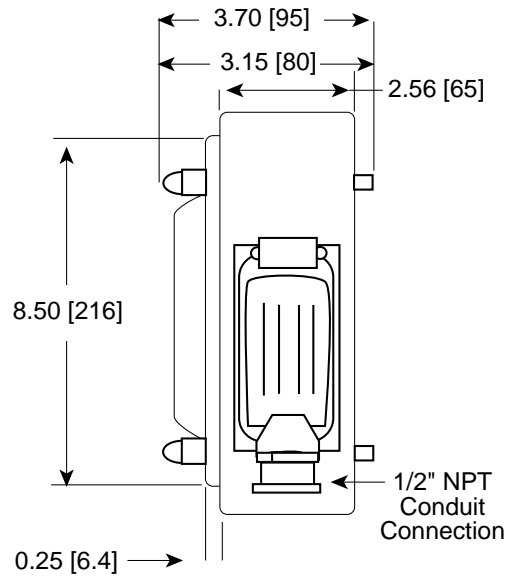

ORDERING INFORMATION

Code 1: Model	Code 2: PPR	Code 3: Index	Code 4: Wheel Bore	Code 5: Output	Code 6: Electrical	Code 7: Termination
R8	<input type="checkbox"/> <input type="checkbox"/> <input type="checkbox"/> <input type="checkbox"/>	<input type="checkbox"/>	<input type="checkbox"/> <input type="checkbox"/> <input type="checkbox"/>	<input type="checkbox"/>	<input type="checkbox"/>	<input type="checkbox"/>
Ordering Information						
R8 Motor Mount Ring, for Nema 8 1/2" C-Face Motors (180C)	0060 0300 0064 0480 0075 0512 0120 0600 0128 0960 0150 1024 0240 1200 0256	L No Index Available when Code 2 is 0480, 0512, 0600, 0960, 1024 or 1200 Z Differential Index (Z, Z̄)	J04 5/8" bore J05 7/8" bore J06 1.00" bore J07 1-1/8" bore K09 1-3/8" bore K10 1-1/2" bore K11 1-5/8" bore K12 1-3/4" bore K13 1-7/8" bore K14 2" bore K15 2-1/8" bore K16 2-1/4" bore K17 2-3/8" bore K18 2-1/2" bore K19 2-7/8" bore Additional Shaft Sizes Available Up to 3.75" Maximum End of Shaft Mounting E01 1.125" EOS E06 2.375" EOS E08 2.625" EOS E10 2.875" EOS	1 Single 2 Dual (Isolated) Differential, bidirectional signals (A, \bar{A} , B, \bar{B})	L 5-15V in, 5-15V Line Driver (4428) out H Same as L with extended temp. to 120°C R 15-26V in, 15V Line Driver (4428) out 5 5-15V in, 5V Line Driver (4428) out	C Latching Industrial Connector with 1/2" NPT M 10 pin MS Connector P 18" Pigtail

Spare Sensor Module: Use "NS" followed by Code 1 (Model) & Code 2 (PPR) & Code 3 (Index) & Code 6 (Electrical) & Code 7 (Termination). Example: NSR80512ZLC
 Spare Pulse Wheel: Use "NS" followed by Code 2 (PPR) & Code 3 (Index) & Code 4 (Bore Size). Example: NS0512ZK11
 Spare Mating Connector: Use "NS" followed by Code 1 (Model) & Code 7 (Termination). Example: NSR8C
 5 foot Interface Cable: RIMCABLEDB10005. Other Length: final 4 digits is length in 5 ft increments. Example RIMCABLEDB10065 is 65 feet.

HEAVY DUTY