

RIM Tach 1250

- Accepts shaft diameters up to 8" - ideal for crane & hoist applications
- Non-contact design mounts directly on motor frame
- Double C face can be sandwiched between motor and brake
- Zero speed sensors are unaffected by grease, salt water, dirt or other common contaminants.



APPLICATION/INDUSTRY

NorthStar's RIM Tach® 1250 digital tachometer provides position and velocity feedback from both AC & DC electric motors, providing precise, reliable speed signals for many monitoring and control applications

DESCRIPTION

The Model 1250 is designed for 12.5 inch diameter type C face motor frames and accessory mounts. This tachometer provides precise, reliable speed signals for many monitoring and control applications and is a standard feedback device for AC & DC variable speed drives. The RIM Tach® 1250 is the process industry's answer to a large thru-shaft option for precise speed control.

Constructed of ductile cast iron, it ensures maximum strength and endurance for possible exposure to acid wash down in pulp and paper applications. The enclosure accommodates both end-of-shaft and thru-shaft mountings and is universally machined to accommodate all sensor modules, regardless of the desired pulse count.

The RIM Tach® 1250 sensor module is engineered to provide a non-contact sensor and electronics in one interchangeable hermetically sealed package. Encapsulated surface mount electronics provide resistance to water, oil, dirt, high temperatures, shock and vibrations and overall harsh environments. The Model 1250 can accommodate up to 2048 pulses per revolution and is bidirectional providing square wave outputs. The sensor module is very simple to change, just remove four screws and slide the new module in place.

There are no bearings to fail or requirements for flexible couplings because its magnetized drum assembly is attached directly to the shaft. The mill duty latching connectors are easy to wire with no need to field solder or to struggle with a crimp pin.

FEATURES AND BENEFITS

- Rugged Mill Duty Construction
- Reliable Magnetoresistive Technology
- Easy Installation
- Modular design for fast, easy field service.
- Resolutions to 2048 PPR - optional Index

SPECIFICATIONS

STANDARD OPERATING CHARACTERISTICS

Code: Incremental
Pulses per Revolution: 60-2048
Phasing Sense: A leads B for Counter-Clockwise rotation (CCW) viewing encoder-mounted end
Quadrature Phasing: 90° ± 22°
Symmetry: 180° ± 54°
Index: 270° gated to falling B edge

ELECTRICAL

Input Power Requirements: 5-15 Volts DC, 45 mA typical per sensor module plus line driver load
Output Signals: Line Driver, 150mA source/sink
Frequency Response: 0 - 120kHz Data & Index
Electrical Immunity: 2kV ESD, Reverse Polarity, Short Circuit
Connector: 10 pin industrial duty latching, sealed NEMA 4 & 12, IP65

ELECTRICAL CONNECTIONS

| Signal | Connector Pin | Pigtail Cable | MS 3102E18-IT# |
|---------------|---------------|---------------|----------------|
| Common | 1 | Black | A |
| B | 2 | Green | E |
| A | 3 | Blue | D |
| Z * | 4 | Violet | C |
| No Connection | 5 | — | — |
| Vcc | 6 | Red | B |
| B̄ | 7 | Yellow | H |
| Ā | 8 | Gray | G |
| Z * | 9 | Orange | I |
| Shield | 10 | Braid | J |

* Index (Z) optional. See Ordering Information

MECHANICAL

Shaft Speed: 7,000 RPM (J or K wheels); 3600 RPM (TL wheels)
Mounting Configuration: 12.5" face mount for NEMA MG1 standards
Housing Material: Cast Iron/Stainless Steel
Acceleration Rate: 3600 rpm/sec max
Shaft Length Required: 3.0" min
Allowable Shaft End-Play: ± 0.050"
Allowable Shaft Runout: 0.003" TIR

ENVIRONMENTAL

Operating Temperature Range: -40°C to +80°C
Storage Temperature Range: -40°C to +120°C
Humidity: to 98% RH (non-condensing)
Shock (Sensor Module): 1 meter drop test, 30 G's Min
Vibration: 18 G's @ 5-2000 Hz spectrum

DIMENSIONS

APPROXIMATE DIMENSIONS (REF): inch [mm]
SHAFT SIZES "D1" ø.826" THRU ø3.260"

| PPR's | CHANNELS: | | SINGLE | | DUAL | |
|-----------------------------|--------------|--------------|---------------|---|------|---|
| | B | A | A | D | D | D |
| 60; 120; 240; 480-Z; 960-Z | 7.72 [196.1] | 7.33 [186.2] | 14.66 [372.4] | | | |
| 64; 128; 256; 512-Z; 1024-Z | 7.87 [199.9] | 7.48 [190.0] | 14.96 [380.0] | | | |
| 75; 150; 300; 600-Z; 1200-Z | 8.28 [210.3] | 7.89 [200.5] | 16.56 [420.4] | | | |

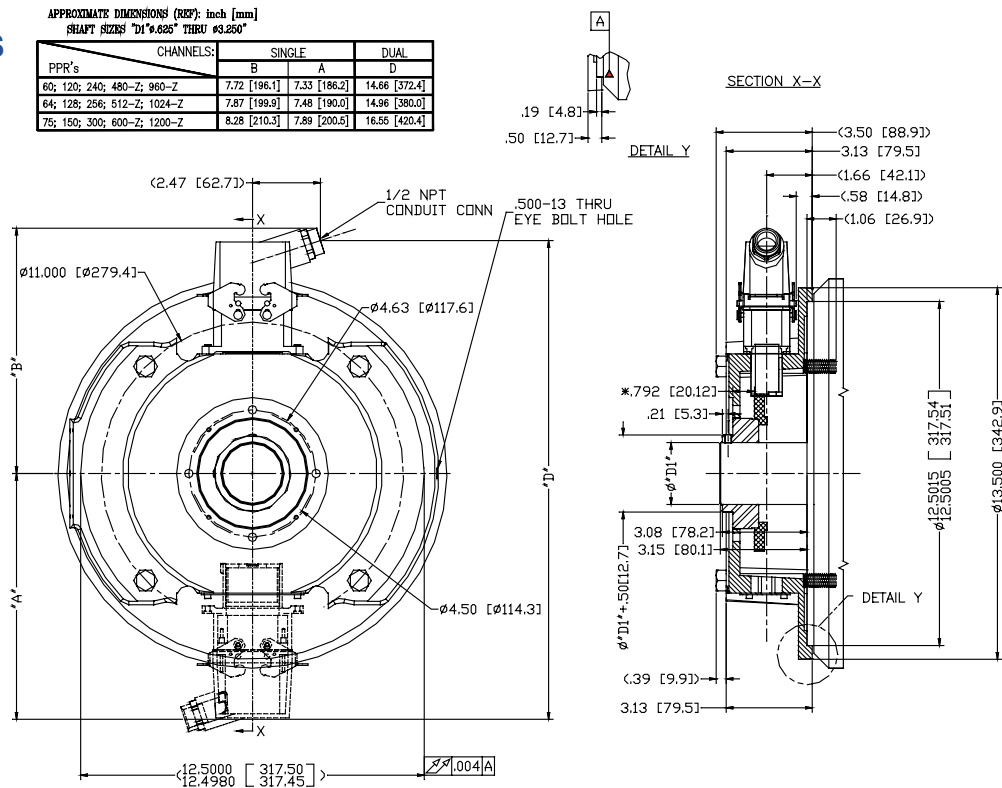

ORDERING INFORMATION

| Code 1: Model | Code 2: PPR | Code 3: Index | Code 4: Wheel Bore | Code 5: Output | Code 6: Electrical | Code 7: Termination | |
|---|--|--|--|---|---|---|--|
| R1 | <input type="checkbox"/> <input type="checkbox"/> <input type="checkbox"/> <input type="checkbox"/> | <input type="checkbox"/> | <input type="checkbox"/> <input type="checkbox"/> <input type="checkbox"/> | <input type="checkbox"/> | <input type="checkbox"/> | <input type="checkbox"/> | |
| Ordering Information | | | | | | | |
| R1 Motor Mount Ring, for 12-1/2" C-Face Motors | 0060 0064 0075 0120 0128 0150 0240 0256 | 0300 0480 0512 0600 0960 1024 1200 2048 | L No Index Available when Code 2 is 0480, 0512, 0600, 0960, 1024, 1200 or 2048 Z Differential Index (Z, Z) | J04 5/8" bore J05 7/8" bore J06 1.00" bore J07 1-1/8" bore K09 1-3/8" bore K10 1-1/2" bore K11 1-5/8" bore K12 1-3/4" bore K13 1-7/8" bore K14 2" bore K15 2-1/8" bore K16 2-1/4" bore K17 2-3/8" bore K18 2-1/2" bore K19 2-7/8" bore Additional Shaft Sizes Available Up to 8.00" Maximum | 1 Single 2 Dual (Isolated) Differential, bidirectional signals (A, A̅, B, B̅) | L 5-15V in, 5-15V Line Driver (4428) out R 15-26V in, 15V Line Driver (4428) out 5 5-15V in, 5V Line Driver (4428) out | C Latching Industrial Connector with 1/2" NPT M 10 pin MS Connector P 18" Pigtail |

Spare sensor module: Use "NS" followed by Code 1 (Model) & Code 2 (PPR) & Code 3 (Index) & Code 6 (Electrical) & Code 7 (Termination). Example: NSR10512ZLC
 Spare Pulse Wheel: Use "NS" followed by Code 2 (PPR) & Code 3 (Index) & Code 4 (Bore Size). Example: NS0512ZK11
 Spare Mating Connector: Use "NS" followed by Code 1 (Model) & Code 7 (Termination). Example: NSR1C
 5 foot Interface Cable: RIMCABLEDB10005. Other Length: final 4 digits is length in 5 ft increments. Example RIMCABLEDB10065 is 65 feet.

HEAVY DUTY