

MagCoder HS35M

- Fits a wide variety of shaft types and sizes
- Fast, easy, flexible mounting
- Reliable magnetoresistive sensor technology
- 128 - 1024 PPR available
- Reverse polarity protected
- Short-circuit protected



APPLICATION/INDUSTRY

The HS35M hollow shaft digital encoder is ideal for motor and machine applications at resolutions to 1024 PPR. Flexible mounting and adjustable anti-rotation arm, provide high tolerance of shaft vibration.

DESCRIPTION

The shaft mounted MagCoder incorporates magnetoresistive technology making it immune to common contaminants such as grease, oil, water, and dirt. It fits a wide variety of motor shaft sizes and is a perfect choice for use in applications requiring accurate velocity feedback.

Its short circuit protection and reverse polarity protection prevent common causes of encoder failure. The HS35M offers a variety of output voltage options, including the choice of regulated output, making it compatible with devices that accept only a specified voltage. An optional high powered line driver is available for further assurance of clear signals over long cable lengths. This unique driver is the strongest offered in the encoder industry.

The entire MagCoder rides on large motor style bearings, maximizing its operational life. Its flexible design allows the encoder to move axially, radially, and at a tangent. It is toughly constructed of stainless steel and epoxy coated zinc alloy. The simple design of the HS35M is pre-aligned, does not require user adjustments, and mounts without accessory hardware, further reducing installation cost and time.

FEATURES AND BENEFITS

- Short circuit protection and reverse polarity protection
- 5-26 VDC operation with bi-directional quadrature and with high power differential line driver outputs
- 128, 256, 512, & 1024 pulses per revolution (PPR) with optional Index pulse
- Up to 80°C operational temperature

SPECIFICATIONS

STANDARD OPERATING CHARACTERISTICS

Code: Incremental
Pulses per Revolution: 128-1024
Phasing Sense: A leads B for Counter-Clockwise rotation (CCW) viewing encoder-mounted end
Quadrature Phasing: 90° ± 22°
Symmetry: 180° ± 54°
Index: 270° gated to falling B edge

ELECTRICAL

Input Voltage Requirement: 5-26 Volts DC
Current Requirement: 45 mA typical plus line driver load
Output Signals:
 With Elec Option 0: 5-26 V Line Driver, 40mA
 With Elec Option 1: 5 V Line Driver, 40mA
 With Elec Option 2: 5-26 V Line Driver, 100mA
Frequency Response: 0 - 120kHz Data & Index
Electrical Immunity: 2kV ESD, Reverse Polarity, Short Circuit
Connector: 10 pin industrial duty latching, sealed NEMA 4 & 12, IP65; or MS connector; or 18" pigtail

MECHANICAL

Shaft Speed: 3,600 RPM
Mounting Configuration: Flexible mount with anti-rotation arm
Housing Material: Stainless steel and epoxy coated zinc alloy
Acceleration Rate: 12,000 rpm/sec max
Available Shaft Sizes: 6 mm to 1.25" thru-shaft style available. See ordering table for sizes.
Allowable Shaft End-Play: ± 0.15"
Allowable Shaft Runout: 0.015" TIR (Subject to RPM Limitation)

ENVIRONMENTAL

Operating Temperature Range: -20°C to +80°C
Storage Temperature Range: -40°C to +120°C
Humidity: to 98% RH (non-condensing)
Shock: 50 Gs for 11 ms
Vibration: 18 Gs @ 5-2000 Hz spectrum

ELECTRICAL CONNECTIONS

Signal	Connector Pin	Pigtail Cable	MS 3102E18-IT#
Vcc (5-26 VDC)	6	Red	D
Common	1	Black	F
A	3	Blue	A
\bar{A}	8	Gray	H
B	2	Green	B
\bar{B}	7	Yellow	I
Z *	4	Violet	C
\bar{Z} *	9	Orange	J
Case (optional)	5	Brown	G
No Connection	10	— —	E

* Index (Z) optional. See Ordering Information

DIMENSIONS
inches [mm]

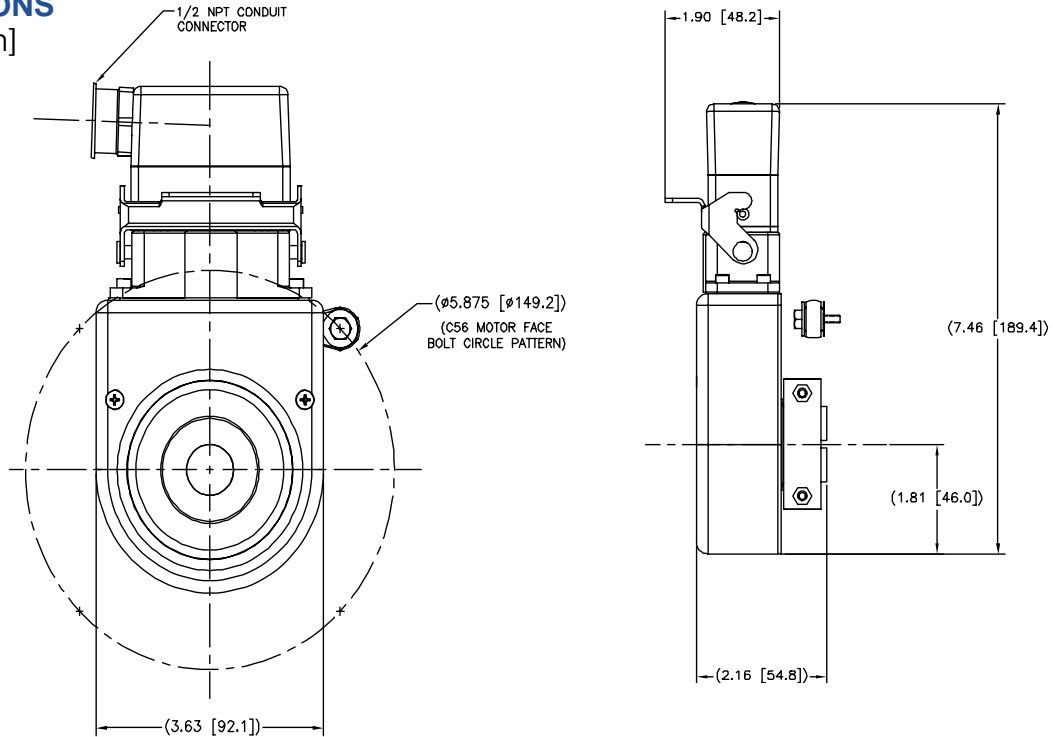

ORDERING INFORMATION

Code 1: Model	Code 2: PPR	Code 3: Index	Code 4: Shaft Bore	Code 5: Termination	Code 6: Electrical	Code 7: Mechanical
MH	<input type="checkbox"/> <input type="checkbox"/> <input type="checkbox"/> <input type="checkbox"/>	<input type="checkbox"/>	<input type="checkbox"/>	<input type="checkbox"/>	<input type="checkbox"/>	<input type="checkbox"/>
Ordering Information						
MH Hollow Shaft Mount	0128 0256 0512 1024	L No Index Available when Code 2 is 1024 Z Differential Index (Z, Z̄)	A 6.0mm bore B 0.250" bore C 0.375" bore D 10mm bore E 12mm bore F 0.500" bore G 14mm bore H 0.625" bore I 16mm bore J 0.750" bore K 25mm bore L 1.000" bore M 1.125" bore P 24mm bore R 28mm bore T 0.875" bore U 1.250" bore V 15mm bore	0 18" pigtail cable 2 Latching Industrial Connector with 1/2" NPT 6 10 pin MS Connector	0 5-26Vin, 5-26V Line Driver (7272) out 1 5-26Vin, 5V Line Driver (7272) out 2 5-26Vin, 5-26V High Current Line Driver out Differential, bidirectional signals (A, A, B, B)	0 Customer Supplied Tether 1 Standard Tether 2 56C Tether 3 180C Tether 8 56C Tether w/ Protective Guard A 180C w/ Protective Guard

HEAVY DUTY

Spare Mating Connector: Use "NS" followed by Code 1 (Model) & Code 5 (Termination). Example: NSMH2
5 foot Interface Cable: RIMCABLEDB10005. Other Length: final 4 digits is length in 5 ft increments. Example RIMCABLEDB10065 is 65 feet.