

"L" Mounting Bracket

- Precision machined aluminum (6061-T6)
- Drilled and tapped where required
- Mounting hardware included
- Encoder can be mounted from either side
- Allows servo ring mount for phasing adjust

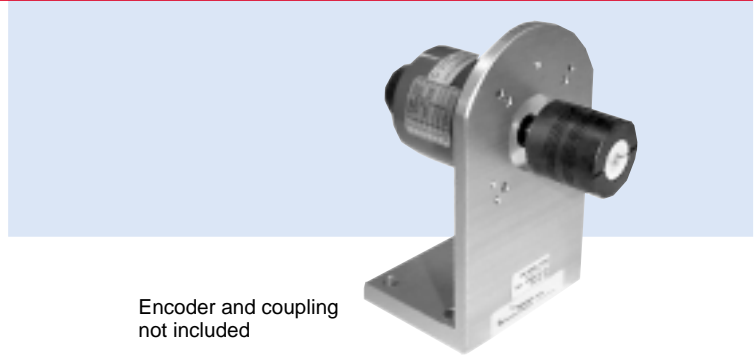

Encoder and coupling not included

APPLICATION/INDUSTRY

Universal bracket allows base mounting of popular Dynapar brand encoders.

DESCRIPTION

Rugged and stable, the bracket is precision machined from 6061-T6 aluminum. Encoder is mounted using drilled and tapped holes which are positioned to accommodate the listed "Compatible Encoders".

Clearance holes are provided for base mounting to a suitable machine surface.

SPECIFICATIONS

DIMENSIONS

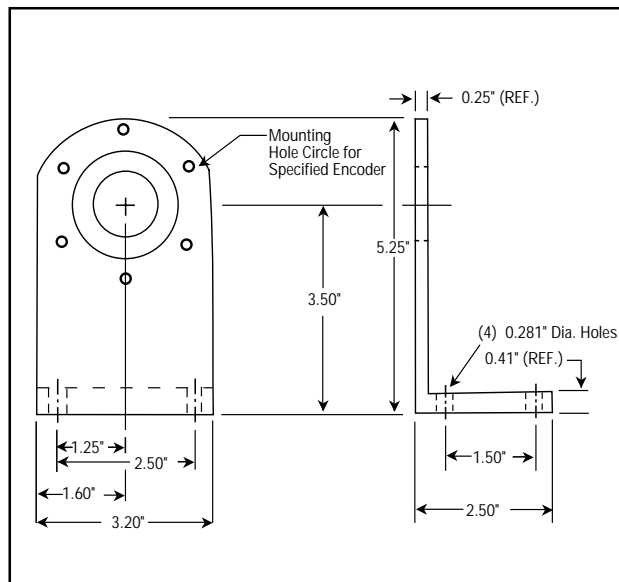

ACCESSORIES

Compatible Encoders

The mounting bracket may be used with the listed series encoders having the specified mounting configurations.

Encoder Series	Mounting Configuration	Figure
14005730000		
60A	All	1
60C	All	1
H42	2.5" Flange	2
H25	2.5" Flange	2
H25	2.5" Servo	3
AI25	2.5" Flange	2
HA725	2.5" Flange	2
108680-0001		
H20	Servo with 1.25" Male Pilot	3
H20	Flange	2
H20	2" BC Face	1
21/22	Except metric	1
108680-0002		
AI25	Face	1
H58	36 mm Pilot	1

Ordering Information

Model No.	Description
14005730000	Mounting Bracket for 60 Rotopulser, 2.5" Encoders
108680-0001	Mounting Bracket for QUBE Encoders
108680-0002	Mounting Bracket for 58mm Face Mount Encoders

INSTALLATION

If during installation, you encounter difficulty in matching the encoder's mount to the features of the bracket, refer to the table on the preceding page to choose the "L" Mounting Bracket part number for compatibility with a specific encoder series and mount configuration.

Figure 1

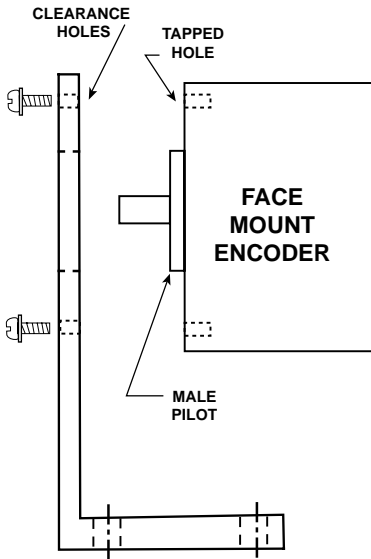

Figure 2

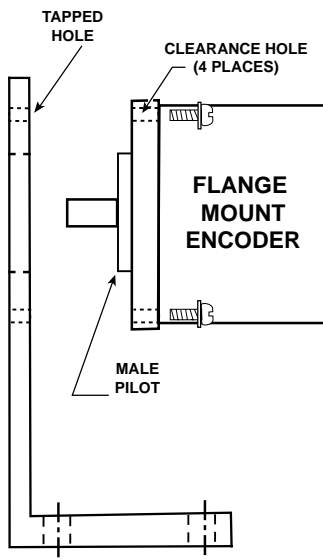
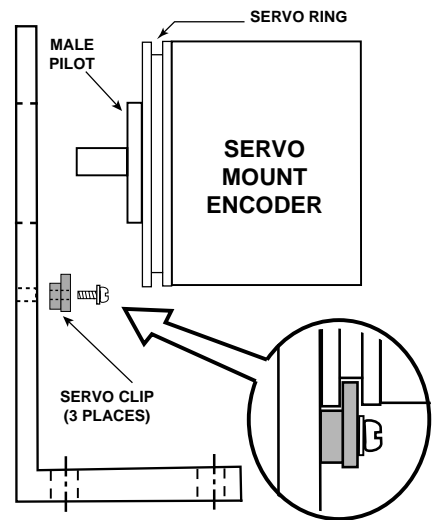

Figure 3



Procedure

- 1) Place encoder's pilot through center hole of bracket. Seat male pilot if provided.
- 2) Align tapped holes in face of encoder with clearance holes in bracket.
- 3) Install pan head machine screws with split lock washers (included) and tighten.

Procedure

- 1) Place encoder's pilot through center hole of bracket. Seat male pilot if provided.
- 2) Align clearance holes in flange of encoder with tapped holes in bracket.
- 3) Install (4) pan head machine screws with split lock washers (included) and tighten.

Procedure

- 1) Install (3) mounting cleats (servo clips) loosely to bracket using pan head machine screws and split lock washers (included).
- 2) Place encoder's pilot through center hole of bracket. Seat male pilot.
- 3) Rotate cleats until they fully engage servo ring groove.
- 4) If encoder has marker index pulse, rotate encoder housing to desired position. Tighten screws.

We strongly recommend use of a precision shaft-coupling to assure maximum performance and to avoid premature failure.



Our CPL Series of flexible shaft couplings ensures long encoder life by restricting transfer of mechanical, thermal, and electrical stress.

A full range of models is available. Each is designed to match specific encoders and is supplied with input-shaft size adaptors.