

NEW

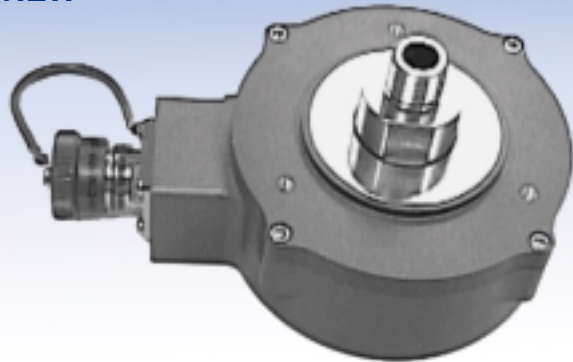

### Harsh-Duty Optical Encoder - DrawWorks

#### DESCRIPTION

The DWD38 Harsh-Duty Optical Encoder is an Industrial Hollow Shaft design that operates reliably from  $-40$  to  $+100^{\circ}\text{C}$ . Its Hard Anodized finish exceeds IP66/IP67 and NEMA 6 enclosure requirements.

The DWD38 is a preferred choice as a DrawWorks encoder by the Oil Field industry and is also commonly used in high shock and vibration environments such as Food Processing, Material Handling and Packaging Equipment applications.

Extremely robust, the DWD38 encoder is also available in Stainless Steel to meet NEMA 4x and 6P requirements. A unique labyrinth double-sealed housing allows operation when regulatory washdown and high pressure steam or caustic chemicals are required.

It is also available in an Intrinsically Safe version, certified to ATEX EEx ia IIB T4, when used with the appropriate IS Barrier.

## Series DWD38

- Single or Dual output - NAMUR available
- Well suited for DrawWorks/oil field application
- ATEX Certification available for Intrinsically Safe application
- High Resolution Unbreakable Disk
- Industrial Duty Connector
- NEMA 4X / IP67 Rated
- Nickel or Stainless Steel Housing available
- Two Year Warranty

#### APPLICATIONS:

The DWD38 Harsh-Duty Optical Encoder is ideal for DrawWorks application and corrosive environments that demand heavy washdown protection. This compact, special-duty encoder is designed to exceed IP66/IP67 and NEMA 6 enclosure requirements with a PPR range through 5000. ATEX certification is also available for intrinsically safe applications.

- DrawWorks and other Oilfield
- Converting Machinery
- Material Handling
- Packaging Equipment
- Pickling Equipment
- Processing Equipment

#### INDUSTRIES

Chemical, Food & Beverage, Oil & Gas, Paper, Steel and any other where a precise encoder is needed to operate in very harsh environments.

#### FEATURES/BENEFITS

Mechanical and Environmental

- Unbreakable code disk
- Flexible mounting
- Heavy duty shaft seals
- Sealed connector

Electrical

- Cast housing maximizes noise immunity and durability
- NAMUR outputs and ATEX certification available



**Harsh-Duty Optical Encoder - DrawWorks**

# Series DWD38

**Harsh-Duty Optical Encoder... Ideal for DrawWorks Application**

## SPECIFICATIONS\*

### STANDARD OPERATING CHARACTERISTICS

Code: Incremental  
**Resolution:** 1 to 5000 PPR (pulses/revolution)  
**Format:** Two channel quadrature (AB) with optional Index (Z), and complementary outputs  
**Phase Sense:** A leads B for CCW shaft rotation viewing the shaft clamp end of the encoder  
**Quadrature Phasing:** 90° ± 15° electrical  
**Symmetry:** 50% ± 5%  
**Waveforms:** Squarewave with rise and fall times less than 1 microsecond into a load capacitance of 1000 pf

### ELECTRICAL

**Input Power:** 5-26VDC; 50 mA max., not including output loads. ATEX: 5VDC, 5-26VDC  
**Outputs:** 2N2222, ET7272, ET7273  
**Frequency Response:** 125 kHz (data & index)  
**Termination:** 6, 7, or 10 pin MS Connector; 18" cable exit w/seal  
**Mating Connector:**  
 6 pin, style MS3106A-14S-6S (MCN-N4);  
 7 pin, style MS3106A-16S-1S (MCN-N5);  
 10 pin, style MS3106A-18-1S (MCN-N6)

**DATA AND INDEX**  
 Not all complements shown.  
 A shown for reference

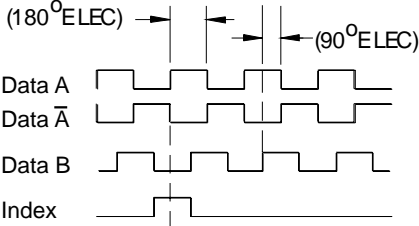

A Leads B CCW

### MECHANICAL

**Shaft Material:** 300 series stainless steel  
**Bore loading:** Up to 20 lbs axial and radial  
**Bore runout:** 0.0005 TIR at midpoint  
**Starting/Running torque:** 4.5/4.0 in-oz. maximum (at 25°C)  
**Bearings:** 61806-ZZ  
**Bearing life:** 5 x 10<sup>8</sup> revs at rated shaft Loading, 5 x 10<sup>11</sup> revs at 10% of rated shaft loading (manufacturers' specs)  
**Housing and cover:** Hard Anodized Aluminum. Also available in Electroless Nickel finish and Stainless Steel.  
**Disc material:** Metal or mylar  
**Weight:** 35 ounces, typical

### ENVIRONMENTAL

**Operating Temperature:** -40 to 100°C  
**Operating Temperature ATEX:** -40 to 80°C  
**Storage temperature:** -40 to 100°C  
**Shock:** 50G's for 11msec duration  
**Vibration:** 5 to 2000Hz @ 20 G's  
**Humidity:** 100%  
**Enclosure Rating:** NEMA 4X, NEMA 6, IP66, IP67. NEMA 6P upon request

\* Specifications are for base models with standard features only unless otherwise noted. Specifications subject to change without notice in accordance with our DBS policy of continuous improvement. All product and brand names are trademarks of their respective owners. All rights reserved.

NorthStar™ brand is a trademark of Danaher Industrial Controls Group. All rights reserved. © 2006 DICG Corp.

NorthStar Brand DWD38 Data Sheet (1/06)

### ELECTRICAL CONNECTIONS

#### 6, 7 & 10 Pin MS Connectors and Cables

Connector & mate/accessory cable assembly pin numbers and wire color information is provided here for reference. Models with direct cable exit carry the color coding as shown in the right hand column.

Encoder Function	Cable # 108594-6 Pin Single Ended		Cable # 108595-7 Pin Single Ended		Cable # 108596-7 Pin Dif Line Drv w/o Idx		Cable # 1400635-10 Pin Dif Line Drv w/ Idx		Cable Exit with Seal
	Pin	Wire Color	Pin	Wire Color	Pin	Wire Color	Pin	Wire Color	
Sig. A	E	BRN	A	BRN	A	BRN	A	BRN	GREEN
Sig. B	D	ORG	B	ORG	B	ORG	B	ORG	BLUE
Sig. Z	C	YEL	C	YEL	—	—	C	YEL	ORANGE
Power +V	B	RED	D	RED	D	RED	D	RED	RED
Com	A	BLK	F	BLK	F	BLK	F	BLK	BLACK
Case	—	—	G	GRN	G	GRN	G	GRN	WHITE
N/C	F	—	E	—	—	—	E	—	—
SigA	—	—	—	—	C	BRN/WHT	H	BRN/WHT	VIOLET
SigB	—	—	—	—	E	ORG/WHT	I	ORG/WHT	BROWN
SigZ	—	—	—	—	—	—	J	YEL/WHT	YELLOW

Headquarters: 1675 Delany Road • Gurnee, IL 60031-1282 • USA  
 Phone: +1 847.662.2666 • Fax: +1 847.662.6633

Satellite Locations:  
 North America: North Carolina, South Carolina, Connecticut, Massachusetts, New York, Canada, British Virgin Islands • Europe: United Kingdom, Italy, France, Germany, Spain, Slovakia • Latin America: Brazil • Asia: China, Japan, Korea, Singapore

**Customer Service:**  
 Tel.: +1.800.873.8731  
 Fax: +1.847.662.4150  
 northstar.custserv@dancon.com

**Technical Support**  
 Tel.: +1.800.234.8731  
 Fax: +1.847.782.5277  
 northstar.techsupport@dancon.com



www.feedbackdevices.com • www.danaherindustrialcontrols.com

**Harsh-Duty Optical Encoder... Ideal for DrawWorks Application**

**DIMENSIONS** inches [mm]

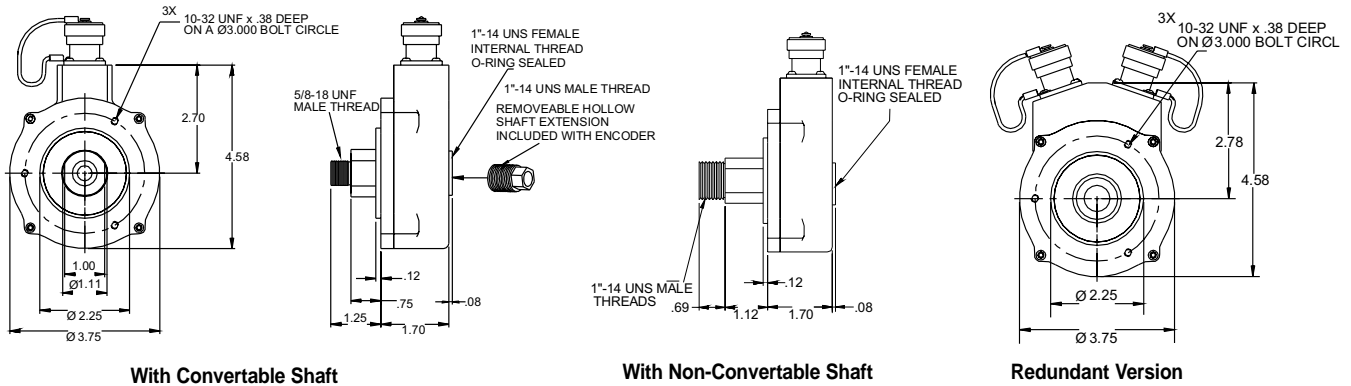

**ORDERING INFORMATION**

Code 1: Model	Code 2: PPR	Code 3: Shaft	Code 4: Electrical	Code 5: Termination	Code 6: Options
<b>DWD38</b> <input type="checkbox"/>	<input type="checkbox"/> <input type="checkbox"/> <input type="checkbox"/> <input type="checkbox"/>	<input type="checkbox"/>	<input type="checkbox"/>	<input type="checkbox"/>	<input type="checkbox"/>
Ordering Information					
Size 38 Harsh-Duty Optical Encoder - DrawWorks	0015 0032 0100 0200 0240 0250 0500 0512 0600 1000 1024 1200 2000 2048 4000 5000	0 1"-14 UNS x 5/8" - 18 UNF Threaded Shaft  1 1"-14 UNS Threaded Shaft	0 5-26V in, 5-26V Open Collector out (7273) 2 5-26V in, 5-26V Push-Pull out F 5-26V in, 5-26V Open Collector out (2222) G 5-26V in, 5-26V Open Collector out with 2.2 kΩ Pullups (2222) N NAMUR 15 mA Maximum  available when: Code 1 is 1,2,4,5,7,8,A or B and Code 5 is 3 through D, or Code 1 is 3,6,9 or C and Code 5 is 5 or D: 3 5-26V in, 5-26V Differential Line Driver out (7272) 4 5-26V in, 5V Differential Line Driver out (7272)	1 6 Pin Connector 3 7 Pin Connector 5 10 Pin Connector D 18" Sealed Cable	0 No Options 1 Nickel Finish Housing 2 Stainless Steel Housing 3 Redundant Outputs (Dual Connector Housing) 4 Nickel Finish Housing with Redundant Outputs 5 Stainless Steel Housing with Redundant Outputs
available when: Code 4 is 0 - 3, F or G					
With ATEX Type 1* Option					
4 Unidirectional 5 Bidirectional 6 Bidirectional with Index					
available when: Code 4 is 4					
With ATEX Type 2* Option					
7 Unidirectional 8 Bidirectional 9 Bidirectional with Index					
available when: Code 4 is 4					
With ATEX Type 3* Option					
A Unidirectional B Bidirectional C Bidirectional with Index					

\*Note: Available ATEX Certified Options

ATEX Type 1: ATEX Certified; 5V in, 5V out only

ATEX Type 2: ATEX Certified; 5-26V in, 5-26V out

ATEX Type 3: ATEX Certified; 5-26V in, 5V out

*Worldwide Brands:*

*Dynapar™*

*Eagle Signal™*

*Harowe™*

*Hengstler™*

*NorthStar™*

*Veeder-Root™*



**A division of  
Danaher, a  
Fortune 500  
company with  
offices in 30  
countries around  
the world.**

**More Available.** With factories around the world, global sales and applications support, and an expansive network of distributors, we stay close to our customers - shortening lead times and fostering responsiveness. Three-day lead time is standard, with same-day shipments available on many of our products.

**More Selection.** We have a broad selection of controllers to meet application requirements in a variety of industries. User-configurable, accurate and flexible, with low, mid, or high level performance ranges, our controller products meet your system and budgetary requirements.

**More Reliable.** Our experience with more than 25,000 customers has taught us to design controllers that are reliable and durable, with quality standards that meet six sigma requirements.

For additional information or a full-line catalog, contact DICG Customer Service or visit our web site.

\* Specifications are for base models with standard features only unless otherwise noted. Specifications subject to change without notice in accordance with our DBS policy of continuous improvement. All product and brand names are trademarks of their respective owners. All rights reserved.

NorthStar™ brand is a trademark of Danaher Industrial Controls Group. All rights reserved.

© 2006 DICG Corp.

Headquarters: 1675 Delany Road • Gurnee, IL 60031-1282 • USA  
Phone: +1 847.662.2666 • Fax: +1 847.662.6633

NorthStar brand DWD38 Data Sheet (1/06)

Satellite Locations:  
North America: North Carolina, South Carolina, Connecticut, Massachusetts, New York, Canada, British Virgin Islands • Europe: United Kingdom, Italy, France, Germany, Spain, Slovakia • Latin America: Brazil • Asia: China, Japan, Korea, Singapore

**Customer Service:**  
Tel.: +1.800.873.8731  
Fax: +1.847.662.4150  
northstar.custserv@dancon.com

**Technical Support**  
Tel.: +1.800.234.8731  
Fax: +1.847.782.5277  
northstar.techsupport@dancon.com



[www.feedbackdevices.com](http://www.feedbackdevices.com) • [www.danaherindustrialcontrols.com](http://www.danaherindustrialcontrols.com)

Factory Automation Worldwide Brands: *Dynapar™* • *Eagle Signal™* • *Harowe™* • *Hengstler™* • *NorthStar™* • *Veeder-Root™*